

***Magellan  
Telescope  
Mirror Cell  
Operations  
Manual***

# TABLE OF CONTENTS

1. **Introduction**
2. **Principles of Operation**
  - 2.1. System Description
  - 2.2. Subsystems Descriptions
    - 2.2.1. Actuators
    - 2.2.2. Hard Points
    - 2.2.3. Static Supports
    - 2.2.4. Thermocouples
    - 2.2.5. Support Air Control
    - 2.2.6. Computer System
3. **Cell Assembly Procedures**
  - 3.1. Mirror Installation and Removal
    - 3.1.1. Vacuum Lifting Fixture
      - 3.1.1.1. Preparation and Checkout
      - 3.1.1.2. Attachment to Mirror
      - 3.1.1.3. Releasing From Mirror
    - 3.1.2. Transport Box
      - 3.1.2.1. Installing Mirror
      - 3.1.2.2. Removing Mirror
    - 3.1.3. Mirror Installation Procedure
    - 3.1.4. Mirror Removal Procedure
  - 3.2. Component Installation Procedures
    - 3.2.1. Actuators
      - 3.2.1.1. Dual-axis and Cross-lateral Actuators
      - 3.2.1.2. Single-axis Actuators
    - 3.2.2. Hardpoints
      - 3.2.2.1. Installations
      - 3.2.2.2. Hardpoint Counterweight Balance Adjustment
      - 3.2.2.3. Load Cell Calibration
    - 3.2.3. Thermocouples
    - 3.2.4. Computer System
    - 3.2.5. Static Support Adjustments
      - 3.2.5.1. Installation
      - 3.2.5.2. Height Adjustment
4. **Operating Procedures**
  - 4.1. Initial Start-up Procedure
  - 4.2. General Operating Procedures
  - 4.3. Computer Interface
    - 4.3.1. Operational Commands
      - 4.3.1.1. Port 5800 Command Summary
      - 4.3.1.2. Port 5801 Command Summary

## **5. Troubleshooting**

- 5.1. Actuators
- 5.2. Hardpoints
- 5.3. Thermocouples
- 5.4. Computer System
- 5.5. Air Control

## **6. Recommended Spare Parts List**

## **7. Test Stand**

- 7.1. General Description
  - 7.1.1. Test Stand Sign Conventions
  - 7.1.2. Criteria
    - 7.1.2.1. Rejection Criteria Implementation
      - 7.1.2.1.1. Single-axis Actuators
      - 7.1.2.1.2. Dual-axis Actuators
      - 7.1.2.1.3. Calibration Test
- 7.2. Software
  - 7.2.1. Description
  - 7.2.2. Calibration
    - 7.2.2.1. Definitions
    - 7.2.2.2. Calibration Procedure
    - 7.2.2.3. Matrix Derivation Procedure
    - 7.2.2.4. Matrix Calculations
    - 7.2.2.5. Revising V\_test Software
    - 7.2.2.6. Testing Matrix Prior to Actuator Calibration
  - 7.2.3. Testing
  - 7.2.4. Test Data
- 7.3. Test Procedures
  - 7.3.1. Single-axis Actuator Test Procedure
    - 7.3.1.1. Overview
    - 7.3.1.2. Detailed Procedure
  - 7.3.2. Dual-axis Actuator Test Procedure
    - 7.3.2.1. Overview
    - 7.3.2.2. Detailed Procedure
- 7.4. Troubleshooting the Test Stand

## **Appendix A Electronic Schematic Drawings**

## 1. Introduction

This manual provides information for the 6.5m mirror and telescope cell, and actuator test stand for the Magellan telescope. The various subsystems, their function, calibration, assembly / disassembly, and troubleshooting guide are provided to assist with the operation of the system.

In addition to this manual the entire mechanical and electrical drawings for the components and assemblies of the system are available at the Steward Observatory web site ([www.as.arizona.edu](http://www.as.arizona.edu)) in the Drawing Archive area.

## 2. Principles of Operation

### 2.1. System Description

The mirror cell system is a complete turnkey system that provides all the necessary hardware and software to support the mirror in the telescope system. The system requires the user to provide pressurized, clean air (nominally 130 psi), and two 20 amp, 115 Vac services to provide power to the air control box and to the computer system. Temperature controlled fluid is required for the thermal control system, but this is not part of the turnkey system.

The software required to run the system is supplied in PROMs installed in the main CPU. These PROMs contain all the software necessary to run the system, but provide nominal settings that allow safe, but not necessarily optimized, operation.

Communications with the system is provided through an Ethernet connection to the computer. Control of the cell as well as gathering information on the status and various parameters relating to the performance of the system is accomplished through the Ethernet connection.

The system supports the mirror by the use of 104 force servo controlled pneumatic actuators, and positions the mirror via six hardpoints configured in a Stewart platform arrangement (essentially three attachment points to the cell and six attachment points to the mirror). The six degrees of force (forces and moments acting in the three planes of space) are derived from loadcells mounted in line between the hardpoints and the mirror. The servo system treats the mirror as a free body mass and varies the forces commanded to the actuators to maintain near zero forces and moments acting on the mirror due to gravity, telescope accelerations and wind loading.

### 2.2. Subsystems Descriptions

#### 2.2.1. Actuators

There are two basic types of actuators used in the system, single and dual axis. The single axis units provide force parallel to the optical axis of the mirror only. The dual axis units have a cylinder identical to a single and a cylinder providing force at a 45° angle. The force exerted by the dual unit is the combined vector force of the normal and 45° cylinders.

The actuators are comprised of a dual ported diaphragm air



cylinder with an integral shaft, two voltage controlled pressure regulators and an S beam load cell for each cylinder and an electronics PC card.

The pressure regulators provide pressure to both sides of the cylinder in a differential manner to allow both compression and tension forces. A bias pressure is applied by both pressure regulators at all times, equal in both regulators for a zero force command.

The load cell provides a force feedback to the analog servo on the PC card. The force servo for each actuator is referred to as the inner loop. Each cylinder in a dual actuator is a separate independent servo loop. The overall force vector required is computed in the main CPU and distributed to each individual cylinder. The electronics card also provides DC-DC converters to supply logic voltage and precision excitation voltage for the load cell. Each card is supplied with 48 VDC and a command voltage for each cylinder on the actuator. The card provides a force feedback from the load cell to the main CPU. This allows the computer to verify the force command sent to each actuator.

The actuators are plumbed with a quick disconnect for servicing the unit. A 10 micron filter is also provided in the air supply line prior to the regulators to help prevent contamination entering the regulators.

Each actuator attaches to the mirror through a single puck or through two-puck or three-puck loadspreaders. All dual actuators attach to the mirror through a three-puck Loadspreader. On single actuators a pressure relief valve is attached to the actuator to prevent excessive force being applied to the mirror.

### 2.2.2. Hardpoints

There are six hardpoints in the cell to provide positioning of the mirror and the loadcell feedback to provide the forces and moments acting on the mirror to the outer servo loop. The hardpoints are designed to breakaway when the force in either tension or compression acting on the hardpoint exceeds a certain level. The exact breakaway force varies slightly between tension and compression and from one unit to the next, but is primarily determined by air pressure applied to the hardpoint.

The hardpoints have a roller screw with a gearbox and stepper motor drive attached to provide a means for changing the length of the hardpoint. The length feedback is provided to the computer by an LVDT. A loadcell is attached in line between the hardpoint and a glass wedge mounted to the mirror. This loadcell provides a force feedback to the main CPU that allows the computer to calculate the forces and moments acting on the mirror. The outer loop servo attempts to zero these forces and moments by applying force to the individual actuators.

A proximity switch is mounted to the hardpoint and interfaced to the stepper motor driver and the main computer to provide travel limits for each of the hardpoints.

The hardpoint is also equipped with a counterweight mechanism that negates the gravity effects of the weight of the hardpoint itself upon the loadcell reading. Effectively this system allows the hardpoint to appear to be weightless to the loadcell. The counterweighting system

consists of two weights that apply varying loads to hardpoint as the elevation angle of the cell is changed.

### 2.2.3. Static Supports

The static supports interface to the mirror through bolts that are attached to the three-puck loadspreaders. The static support provides a limit to the range of motion of the mirror in all directions and provides a safe platform for the mirror to set down upon should the support system fail to support the mirror for any reason.

The unit is adjustable from beneath the cell top plate and is accurately positioned in each location to ensure that the static supports contact the bolts at as close to the same point in motion to provide equal loading on all bolts.

### 2.2.4. Thermocouples

There are 112 Type T thermocouples (TCs) located in the mirror and cell to provide temperature information for the thermal control system. In the mirror selected cells have three TCs mounted on the back of the faceplate, the sidewall and the top of the backplate. One TC is located in each of the separate bays inside the cell weldment. The remaining TCs are on the top plate of the cell below the mirror and around the perimeter of the top of the cell weldment to provide ambient temperature feedback.

The TCs in the mirror, on the plate, and reading ambient are fed through 50 pin D-subminiature connectors in the top plate of the cell. When installing or removing the mirror, the connectors attached to the TCs mounted in the mirror need to be connected / disconnected.

All TCs are fed to a common Isothermal Junction Block (IJB) where the conversion from TC wire to copper wire is made. The IJB temperature is measured via an AD590 current source. The TCs are multiplexed and input to the 16 bit ADC.

### 2.2.5. Support Air Control

The compressed air is divided into five separate feeds, four sectors to supply air to the support actuators and one feed to all six hardpoints. The air supply and 48 VDC Power supplies are separated into four sectors and then distributed to the actuators such that like color actuators are not clustered together. This is done so that if any one of the power supplies fails then the mirror will not be damaged, but will remain supported so that the mirror can be brought down in a controlled fashion.

Due to the color of the tubing used to plumb the air to the actuators the loops are referred to as the Red, Blue, Orange and Yellow loops. When the system is given a command to turn the air on, each of the loops is brought up one at a time, the actuators in that loop are commanded and evaluated for proper operation prior to the next loop being pressurized.

Each of the sector air supplies is controlled by the computer through a solenoid valve. The hardpoint supply is also regulated to provide the correct air pressure to the hardpoints for proper breakaway

operation. When a condition is detected in the system that indicates a component failure or other dangerous loading to the glass the computer will immediately vent the air supply to the actuators through the Air Control solenoid valves.

The Air Control Box requires a separate 120 VAC supply for proper operation of the system.

#### 2.2.6. Computer System

The computer box houses the main VME computer chassis, the four 48 VDC power supplies for the actuators, a triple supply that outputs +5 VDC and +/- 15 VDC logic supplies to the computer system, a +/- 12 VDC supply for the VME bus and hardpoint loadcells and LVDTs, and a +20 VDC supply for the hardpoint stepper motors.

An interface panel on the computer box and a similar one located on the side of the cell provide a means for interconnecting the computer to the cell.

The computer consists of a Motorola MVME-167 CPU, an Acromag 9330 16 bit ADC used to read the hardpoint loadcells and LVDTs and the TCs, and an IP carrier with DIGI-48 I/O modules and a 12 bit ADC for reading the actuator force monitors, a Steward Observatory built IP Translation board that handles the watchdog timer, control logic addressing, integrator lockout signals and line drivers, and eight Steward Observatory built DAC cards that provide the DC command signal to each of the actuators.

Located within the cell weldment are sector distribution cards that distribute power and the DAC output commands to each of the actuators, a cell distribution card, a set of sector distribution cards and a force monitor card that multiplexes the force monitor signals from each of the actuators. Mounted near each of the hardpoints are the amplifier for the loadcells, the demodulator card for the LVDTs and the driver for the stepper motor.

### 3. Cell Assembly Procedures

#### 3.1. Mirror Installation and Removal

##### 3.1.1. Vacuum Lifting Fixture

##### 3.1.1.1. Preparation and Check-out

These are general guidelines to be used when setting up and checking out the 6.5m Vacuum Lifting Fixture. This procedure takes for granted that good plumbing techniques have been followed during initial set-up of the fixture.

1. Mechanical set-up.
2. All bolts must be torqued to their proper values during assembly.
3. All plumbing fittings should be doped, not taped, during assembly. Experience has shown that tape can clog the orifices in the vacuum pumps.
4. Apply anti-seize compound to the center pivots on the 6 substars (spherical bushings) before assembly.
5. Apply Anti-seize compound to the ball ends of the pad pivot bolts during assembly.

6. When installing the pads, run the nut down so bolt threads just show at the top of the nut.
7. During initial set-up, the pad mounting angles must be adjusted for a good fit (normal) to the mirror surface.
8. Plumbing.
9. Quality pipe thread sealant should be used for assembly rather than Teflon tape.
10. Baggies or some suitable substitute must protect all couplings during assembly, as dirt will prevent good connections and cause accelerated leak rates.
11. Plumb the pads in pairs, color coded to each vacuum sector. Each substar should have 3 colors of plumbing run to it, with same-color substars at 120 degrees to each other.
12. Cable ties should be used to secure loose hoses to the fixture.
13. Run the pumps individually to test for performance.
14. Electrical connections must be made following good, standardized practices.
15. Overnight testing of the system attached to the mirror is mandatory. Check for tools on the fixture before attaching it to the mirror.

#### 3.1.1.2. Attachment to Mirror

1. Attach crane scale plus the 3-to-6 legged, color-coded sling to the crane. The order of assembly is as follows: hook, large 55 ton shackle, crane scale, small 55 ton (red and yellow) shackle, 3-to-6 legged color-coded sling. Shackles on the end of the 6 legs should be the large 12 tons followed by the small alloy 12.5 tons. These are what connect to the vacuum lifting fixture.
2. Attach the lifting fixture to the rigging and lift. Level fixture to within .25 inch with shot bags.
3. Clean the lifting fixture (usually with rags and compressed air outside).
4. Verify all connections from the mirror to the cell are disconnected.
5. Record the scale reading. It should be approximately 15,800 lbs.
6. Rotate substars so the Alpha designations are facing out and are centered on the 18-inch beam.
7. Tilt the substars 7 degrees and stabilize with bungee cords.
8. Record the scale reading. Again, it should be apx. 15,800 lbs.
9. Check the fixture for tools, etc.
10. Tare out the crane scale to read zero.
11. Check all 6 ball valves to insure that they are closed.
12. Close master bleed valve.
13. Perform final inspection of mirror surface for particles.
14. Set vacuum pump power switches to 'on' position.

15. Vacuum pump vacuum/release switches to release (this blows air out the pads).
16. Master power switch off.
17. Plug in the master power box to 3 independent circuits.
18. Master power switch 'on' (this starts the pumps).
19. Master bleed valve open (this clears all vacuum from the reserve tanks).
20. Master power switch off.
21. Center the fixture to the mirror (2mm) without contacting the mirror surface.
22. Master power switch 'on' (pads should be blowing air out).
23. Lower the lifting fixture until the ball bolt nuts (they attach the pads to the spider) have about .5 inch gap between them and the spider arm. Do not rest the fixture on the mirror. The crane will read approximately -1000 lbs.
24. Check to see that all the ball bolts are perpendicular to the mirror surface and centered in their holes. Minimum .25 inch clearance.
25. Master power switch off.
26. Adjust the ball bolt nuts so that they all have approximately 1.5-inch gap between them and the substar.
27. Record the crane scale reading.
28. Set the vacuum pump vacuum/release switches to vacuum.
29. Record all 6 vacuum readings.
30. Jog master switch for 5 seconds and check for contact at both the vacuum pad and the substar interface. No contact is allowed. Repeat until 15 inches of vacuum is achieved, checking contact and that the sectors are within 2 inches of vacuum to each other. Once 15 inches is achieved, more than 2 inches difference between sectors is allowed. Re-adjust crane if necessary to keep ball bolt nuts evenly spaced.
31. Check that all ball bolts are perpendicular and centered.
32. Turn the master switch on for 10 minutes.
33. Record all 6 vacuum readings.
34. Let sit for 10 minutes.
35. Raise crane to where the ball bolt nuts are about to contact substars.
36. Adjust ball bolt nuts by hand until all are evenly tight.
37. Record all 6 vacuum readings. If any have dropped appreciably, detach lifting fixture by procedure "Releasing From Mirror" and repair.
38. Turn the master switch on for 30 minutes.
39. Set master switch off.
40. Record all 6 vacuum readings.
41. Let sit for 4 to 16 hours. If any circuit has dropped more than .25 inch per hour, find and repair leak. Do not purposely release one sector. If release is necessary, accomplish using release procedure.
42. Record all 6 vacuum readings.
43. Set master switch on for 30 minutes.

44. Record all 6 vacuum readings. At this point, vacuum must exceed 24 inches.
45. Make sure of emergency set-down procedure.
46. Lift the mirror, stopping for frequent inspections for interference.
47. When the mirror is free of all supports, record crane scale.
48. Level mirror with shot bags and record final weight.  
Failure of one vacuum sector can be tolerated when the mirror is on the crane. If two sectors fail, the mirror must be set down on the foam pads with all deliberate haste. A vacuum sector is considered failed when it has less than 10 inches of vacuum on the gauge. The fixture should be detached by following "Releasing From Mirror" if two or more circuits have failed.

Failure of individual or total circuit power does not mean the vacuum circuit is in immediate danger. The leak rate test will allow 24 hours before you must set the mirror down. The mirror should not be left unattended. Check the vacuum gauges and the pump operation every 30 minutes. Extended periods of hanging the mirror with pumps operating is quite safe. It is better, however, to run the pumps for 10 minutes every hour rather than to leave them running for extended periods, although running the pumps for days is safe. If one pump fails but the vacuum is intact, open the ball valve between the 2 sectors and turn on the active pump. **Do not open all 6 valves.**

#### 3.1.1.3. Releasing From Mirror

1. Set the mirror down according to the appropriate procedure.
2. Lower the fixture until there is .5 inch of clearance under the ball bolt nuts. Do not allow the fixture to rest on the mirror. The crane scale should read 0 pounds.
3. Remove all of the mirror leveling shot bags. Leave the fixture leveling bags.
4. Set the mast power switch to off.
5. Open all 6 ball valves.
6. Open the master bleed valve.
7. Keep checking the clearance between the pads and the substars. Do not allow contact. Adjust crane height if required.
8. Once the system is down to 2 inches of vacuum, it is safe to leave the fixture hanging for extended periods unattended. If the fixture is to be lifted off, continue with the procedure.
9. Turn master power switch off.
10. Set all 6 vacuum/release switches to 'release'.
11. Return the master power switch to the 'on' position.
12. With the pumps still running, lift the fixture away from the mirror.
13. Turn the master switch off.

### 3.1.2. Transport Box

#### 3.1.2.1. Installing Mirror

*Personnel required:* 1 crane operator, 1 inside spotter and 6 mirror spotters. Set-up vacuum lifting fixture attached according to procedure "Attachment to Mirror".

1. Place the 6 mirror spotters around the mirror. Place spotter on ladder in center hole.
2. Place 6 PVC tubes between mirror and cell walls, spread evenly around the circumference.
3. Read the crane scale. This should be 0 or some small negative number.
4. Set the master power switch on.
5. Take up load with crane (it should lift around 20,000 lbs).
6. Lift the mirror slowly from the cell, checking for any dangling items that may catch. Crane operator should watch for any sudden changes in crane scale reading.
7. Lift mirror clear of cell and transport box.
8. Place cell on appropriate supports.
9. Install transport box onto aircraft using required supports.
10. Inspect all interfaces, box and mirror for interference.
11. Center transport box under mirror.
12. Lower mirror to 1 inch above interfaces. Adjust in X, Y and rotation until good fit is achieved.
13. Loosen interface bolts and raise them to meet the mirror.
14. Install 2 bolts in each interface and tighten.
15. Unload crane onto the box, watching for any interference.
16. Remove lifting fixture by following procedure "Releasing From Mirror".

#### 3.1.2.2. Removing Mirror

Set-up: The vacuum lifting fixture is attached according to procedure "Attachment to Mirror". All aft and side covers, and the box lid, must be removed before starting.

1. Place the spotters around the mirror at the 6 substars. These spotters should be looking at the blue interface arms during the lift.
2. Place the inside spotter where they can see the mirror surface and all 6 substars. This spotter is looking for any problems with the substars or the vacuum pads on the mirror.
3. Crane scale should be set to zero or, if using a hydraset, not the starting value. The Magellan I primary mirror weighs 21,400 lbs.
4. Remove all the 3/8-inch bolts holding the blue transport box arms to the mirror loadspreaders.
5. Double check that all bolts have been removed.
6. Take up mirror load on the crane in slow speed. Crane operator must watch the scale or hydraset for any sudden load changes.

7. The mirror should clear the supports when the scale reads the above noted weight.
8. Remove and store with the box hardware the special aluminum interfaces attached to 4 mirror loadspreaders. These stay with the box.
9. Once clear of all blue box interfaces, lift the mirror clear of the box extension arms located at the 4 corners of the box frame before translating the mirror in X or Y.

Keep all box hardware together. After the mirror is clear of the box, remove all 3/8-inch hex bolts from both the 3-puck and 2-puck loadspreaders. These are for transport only and are not used in the telescope. Include this hardware when the box is returned to the Mirror Lab. Re-install the box lid and aft and side covers as soon as possible to keep the box clean.

### 3.1.3. Mirror Installation Procedure

The purpose of this section is to describe the standard installation procedure for the 6.5m primary mirror into the Magellan I telescope cell.

The procedure assumes that the vacuum fixture has been installed and checked out following the appropriate procedure. The cell has been checked for any obstructions such as tools, etc. on the cell faceplate. Any bent ventilation nozzles have been removed as they can be caught by loadspreaders as the mirror is lowered into position. Tuck the thermocouple wires up inside the mirror to keep them from dangling in the way.

*Personnel:* 1 crane operator, 1 inside spotter, 1 procedure person and 6 mirror spotters

1. Locate the 6 spotters around the cell so they have access to the top of the cell and can see down into it.
2. Position the inside spotter in the center hole of the cell.
3. Have the mirror spotters install the lightweight PVC bumpers down the side of the cell. These will protect the mirror from contacting the cell.
4. Remove the mirror from the transport box using procedure "Removing Mirror".
5. Remove all 3/8-16 hex bolts from the loadspreaders. These were installed for shipping only.
6. Check all of the mirror interfaces to be sure they are clear of any obstructions.
7. Center the mirror over the cell by eye.
8. Clock the mirror to the cell using hardpoint locations as reference.
9. Lower the mirror to 12 inches above the cell.
10. Install 3 plumb bobs at 3 single-axis actuator locations, using the interface on the mirror as the center for the bob. These bobs will center the mirror more precisely. Allow 3 feet of line between the bobs and the mirror.



11. Adjust X-Y of the mirror for centering of the plumb bobs in the cell faceplate perforation.
12. Lower the mirror slowly to 6 inches above the static supports, watching the crane scale or hydraset value at all times.
13. Remove the thermocouple connectors from their respective holes and lay them on the cell faceplate so they are out of the way of the descending mirror.
14. Have the inside spotter perform a thorough visual inspection to assure there is no interference.
15. Lower the mirror to 1mm above the static supports, watching the crane scale or hydraset value at all times.
16. Install 3 guide rods into 3 loadspreader puck locations 120 degrees apart around the outer edge of the mirror. Small adjustments in X, Y and clocking may be needed.
17. Using the slowest crane speed, lower the mirror to contact the static supports.
18. Watching the value of the crane scale or hydraset, unload the mirror weight plus 1000 lbs. onto the cell. This should be done with the 6 mirror spotters now watching the vacuum lifting fixture substars.
19. Remove the vacuum lifting fixture from the mirror using procedure "Releasing From Mirror".
20. Clear lifting apparatus from the mirror before proceeding.
21. Remove the PVC bumpers from the cell.
22. Install static support bolts. This should be done in a systematic way. Torque the bolts to 15 ft/lbs.
23. Install all remaining ventilation nozzles.
24. Install the 6 hardpoints by following procedure "Hardpoints Installation".
25. Install the actuators using procedure "Actuators".
26. Connect thermocouple connectors.

The Mirror systems are now ready for checkout using the appropriate procedures.

#### 3.1.4. Mirror Removal Procedure

The purpose of this section is to describe the standard removal procedure for the 6.5m primary mirror from the Magellan I telescope cell. The procedure is essentially the reverse of the installation procedure, with some of the mirror guiding and alignment steps removed.

The procedure assumes the vacuum fixture has been attached to the mirror and checked out following the appropriate procedure. It is also suggested to weigh the fixture and note the value prior to removing the mirror.

*Personnel:* 1 crane operator, 1 inside spotter, 1 procedure person and 6 mirror spotters.

1. Remove all the bent air nozzles from the cell
2. Disconnect the thermocouple connectors attached to the mirror thermocouples.

3. Remove the static support bolts. This must be done in a systematic way to ensure that no bolts remain in the cell. This should be double and triple checked by various individuals. A single or a few bolts remaining attached to the mirror could cause severe damage to the mirror when lifting with the crane.
4. Disconnect and remove the six hardpoints following the reverse of the "Hardpoints Installation" procedure.
5. Remove all actuators from the cell following the reverse of the procedure in the following section "Component Installation Procedures-Actuators"
6. Install the PVC bumpers between the cell and mirror to protect the mirror from contacting the cell when removing it.
7. Attach the lifting fixture to the mirror using the procedure "Attachment to the Mirror" in the Vacuum Lifting Fixture" section 3.1.1.2.
8. Watching the crane scale or hydraset, load the crane to the weight of the lifting fixture.
9. With the spotters in place around the perimeter of the mirror/cell slowly increase the crane load until it has been loaded to the weight of the fixture plus mirror. As the weight is increased the static supports should deflect up as the mirror weight loading them is reduced.
10. Once the crane has been loaded to the fixture plus mirror weight, using the slowest possible crane speed, slowly lift the mirror until it can be verified that the mirror is free of all static supports.
11. After it is verified the mirror is completely free of the static supports the lifting fixture / mirror can be lifted out of the cell. Once clear of the cell remove the PVC bumpers and tuck the thermocouple wire / connectors into the mirror to prevent damage.

## 3.2. Component Installation Procedures

### 3.2.1 Actuators

These procedures cover the installation procedures for all 6.5m telescope cell actuators. It is assumed that the person performing this operating has some working knowledge of the cell. A more experienced person must supervise anyone performing this operation for the first time.

#### 3.2.1.1. Dual-axis and Cross-lateral Actuators

1. Loosen actuator electronics board screws (4) and let the board dangle to the side of the assembly.
2. Install the actuator onto the installation jack on the proper interface.
3. Position actuator under the location to be installed.
4. Orient the actuator by checking which way the actuator should face (top or bottom horizon pointing) or sideways for the 4 cross-laterals.
5. Carefully raise actuator with the jack, watching for interference with cables, hoses, pipes or the cell itself.

6. When close enough, engage the locating pins by pushing the actuator into position by hand. This prevents bent pins and is **very** important.
7. Install the 4 hold-down bolts.
8. Torque the bolts to 15 ft/lbs.
9. Make the interface connection by pushing up on the ends of the 2 cylinder rods until you feel the pins engage the interface.
10. Install two (2) 3/8-16 s.s.s.h.c.s. and torque to 15 ft/lbs.
11. Tuck the loose load cell cables into the cavity in the actuator and install the electronics board.
12. Install the proper airline connection by reading the connector i.d. number and matching it to the actuator being installed. Do the same for the electronics connector.
13. Do a visual check to make sure no wires or airlines are pinched.
14. Actuator installation is now complete.

#### 3.2.1.2. Single-axis Actuators

1. Verify that the correct actuator is being installed.
2. Check that a trantorque is installed on the end of the actuator interface stud.
3. Locate the actuator to the interface pins by hand, watching that the trantorque fits up into the mirror interface.
4. Install three (3) 3/8-16 s.s.s.h.c.s. and torque to 15 ft/lbs.
5. By hand, push the rod of the air cylinder up until it bottoms out.
6. While holding the rod up, reach up above actuator and tighten the trantorque.
7. Install the proper airline connection by reading the connector i.d. number and matching it to the actuator being installed. Do the same for the electronics connector.
8. Do a visual check to make sure no wires or airlines are pinched.
9. Actuator installation is now complete.

Removal of actuators is performed by simply reversing the appropriate procedure given above.

#### 3.2.2. Hardpoints

The purpose of this procedure is to describe the hardpoint installation and adjustment procedure for the 6.5m telescope cells. This document assumes a working knowledge of the cell by the person performing the operations. A more experienced person **must** supervise anyone performing this operation for the first time.

### 3.2.2.1. Installation

1. Identify the correct hardpoint for the location to be installed.
2. Check that the correct flexure is installed on the upper and lower hardpoint interfaces. These are numbers to correspond to the hardpoint they go with.
3. Install protective shims in the lower fixture. These protect the flexure from being bent. This is very important.
4. Install the hardpoint onto the jacking fixture with the motor up.
5. Verify that the upper and lower clamps match the hardpoint to be installed.
6. Verify that the zenith and horizon counterweight arms are ready to be connected. They should be close to the position in which they normally rest.
7. Check that the horizon weight is free to move. The zenith weight arm should be clamped in such a way that it is in the center of its range-of-motion.
8. Position the hardpoint under the location to be installed.
9. Raise the hardpoint slowly, watching for any interference that might occur.
10. Maneuver the hardpoint over the lower flexure. Done properly, the lower connection should drop down onto the seat of the lower flexure while the upper connection is in line with the upper flexure.
11. Adjust tilt until upper connection is aligned, but do not make the connection.
12. Install the lower clamp, but do not tighten at this point.
13. Attach the horizon and zenith counterweight connections.
14. Remove the safety strap on the transmission jack.
15. Check that the hardpoint is now floating on the zenith counterweight.
16. Adjust the clocking of the hardpoint to approximately 90 degrees on the side of the counterweight connection plate.
17. Snug up the lower clamp.
18. Remove the transmission jack.
19. Make the upper connection by pushing out the end of the hardpoint (breakaway) until it seats on the upper flexure.
20. Install the upper clamp, but do not tighten.
21. Adjust the clocking again to 90 degrees on the side of the counterweight connection plate.
22. Tighten the upper and lower clamps.
23. Remove the protective shims from the lower flexure.
24. Connect the breakaway air supply. It is the clear airline.
25. Connect the load cell and the hardpoint electronics.
26. Hardpoint is now installed.

### 3.2.2.2. Hardpoint Counterweight Balance Adjustment

1. Install hardpoint following the above procedure thru step #18.
2. Install the counterweight balance adjustment weight. Note: This is a weight that is clamped to the hardpoint at a specific point to represent the weight of the upper flexure assembly, which needs to be accounted for in the counterweight trim weight assembly.
3. Install enough trim weights to make the hardpoint float.
4. Remove the protective shims from the lower flexure.
5. Check the balance again and adjust if needed.
6. Make the upper connection by pushing out the end of the hardpoint (breakaway) until it sits on the upper flexure.
7. Install the upper clamp, but do not tighten.
8. Remove the counterweight balance adjustment weight.
9. Adjust the clocking again to 90 degrees on the side of the counterweight connection plate.
10. Tighten the upper and lower clamps.
11. Remove the protective shims from the lower flexure.
12. Connect the breakaway air supply. It is the clear airline.
13. Connect the load cell and the hardpoint electronics.
14. Hardpoint is now installed.

### 3.2.2.3. Load Cell Calibration

The hardpoint loadcells are mounted in a housing that provides the mechanical interface to the mirror and hardpoint. This housing, however, imparts a force on the loadcell that is measured at all times and would appear as an offset in the outer loop servo. In addition the weight of the load cell and housing hanging off the mirror is also measured by the loadcell. It is therefore necessary to null this offset so that the outer loop servos to a true zero load acting on the mirror.

1. Attach the six loadcells assembled in the flexure housing assembly to the primary mirror.
2. Connect the hardpoint loadcell cable from the loadcell to the preamplifier.
3. The loadcells should not be connected to the hardpoints, but be free hanging with the computer system powered up and running.
4. After logging into the cell computer at the prompt type in the command `show_hplc`.
5. A list of six rows of numbers will be displayed beginning with `ch0` and ending with `ch5`. The value associated with each channel should be recorded.
6. In the `cell_setup.c` file and array called "`hpreload[]`" should be modified to reflect the numbers previously recorded. This will be the new offsets for the hardpoint loadcells.

7. After making and saving the changes the software should be rebuilt using the "make" command.
8. Any time that a hardpoint loadcell is changed or has to be disassembled from its housing this procedure must be repeated to prevent a bias occurring in the outer loops.

### 3.2.3 Thermocouples

The only issue regarding installation of the thermocouples is to connect the mirror thermocouple D-subminiature connectors to the mating connector on the interface plate of the cell top plate when the mirror is installed or disconnecting them prior to mirror removal from the cell. All other thermocouples are already installed in the system when it is delivered. There are six interface plates with 12 D-sub connectors in the top plate. Most of these connectors are for mirror thermocouples and the remaining connectors are for ambient and upper plenum thermocouples.

### 3.2.3. Computer System

The computer system box must be mounted to the side of the cell with the hardware supplied and mounted on the cell. The set of cabling that runs from the computer box to the cell interface plate is labeled at each end and also keyed such that there is only one configuration allowable. The keying prevents the cable ends from being swapped and also from installing the wrong cable to the connectors on the interface plates. Care should be taken, however, to avoid forcing the connectors into a mating connector that is not keyed properly and to avoid dropping the connector housing which could result in damage to the connector preventing it from mating.

### 3.2.5. Static Support Adjustments

This section covers the installation and adjustment of static supports in the 6.5m telescope cells. Current assembly drawings must be in hand to use this procedure. The endnotes are specific to the Magellan I installation at the site and should be used only for that application.

#### 3.2.5.1. Installation

1. Install 3 static supports around the 3-puck loadspreader location. Leave the ¼-28 screws loose.
2. Place actuator locating jigs in the location being installed and the location adjacent it.
3. Insert the 2-inch pipe locators. These are part of the jig assemblies.
4. Install the static support jig onto the 2 pots. The jig should slide down over the posts.
5. Move the static supports around until they line up with the 3 holes in the jig plate.

6. Insert locating pins through the jigs and into the static supports.
7. Tighten the hold-down screws of the static supports.
9. Remove the jigs and repeat until the entire cell is populated.

#### 3.2.5.2. Height Adjustment

1. The cell must be level with respect to gravity to perform this adjustment.
2. Install the auto-level (or some other like instrument) in the center hole of the cell.
3. Take and record the heights of the reference pads located around the outside of the cell faceplate.
4. Install height gauge onto a static support.
5. Using the drawing and known offset, adjust the interface bolt up or down to achieve the appropriate height.
6. Lock the adjustment in place using the 2 brass nuts.

Note: For the adjustment to be made for Magellan I when it arrives at the site, the height needed is 2.77mm above the current set plane. This will position the mirror vertex to the value set forth in the Technical Specifications, Document #95PR0014, page 3, para. 1.2.

## 4. Operating Procedures

### 4.1. Initial Start-up Procedure

The recommended start up sequence for the mirror support system is to energize the two 120 VAC power feeds, allowing the computer to fully boot and then apply the 130 psi pressurized air to the system. It is not absolutely necessary to follow this sequence, but in the event of a problem with the computer no air, and therefore no force, can be applied to the mirror.

### 4.2. General Operating Procedures

All mirror control functions, system status, parameter values and bias values to the nominal force set can be interfaced to the system via the Ethernet connection and the two ports described in the following section. In general the cell is provided with a pre-established operating position that effectively centers the mirror in the cell. The raise command will raise the mirror to this operating point and close the outer loop servos automatically. Other inputs allow the mirror to be lowered in a control fashion, or provide a panic command that sets the mirror down on the static supports rapidly by venting the pressurized air to the system.

Other functions in the command set allow for various parameters in the system to be monitored, gathering of data while the system is operating to gauge the performance of various aspects of the system, and to set various user adjustable parameters in the system.

## 4.3. Computer Interface

### 4.3.1. Operational Commands

In order for external systems to communicate with the mirror cell, a set of network interfaces have been implemented in the control software. These interfaces monitor two TCP/IP ports, awaiting commands from the external system, and responding to them as appropriate. The ports defined for these purposes are: 5800 for “normal” requests and 5801 to request various error data.

Commands are passed to the mirror cell by using defined symbolic constants to represent the commands. The commands recognized by the mirror cell and the symbolic constants associated with them are defined in the file `cell_net.h` and summarized below. The table below also details any arguments that are passed along with the command and the responses that are returned by the mirror cell system.

#### 4.3.1.1. Port 5800 Command Summary

**CMD \_ RAISE** – Raise the mirror into operating position. No arguments

**CMD \_ PARK** – Lower the mirror back to it’s “parked” position. No arguments

**CMD \_ PANIC** – Cause a “panic stop”. The mirror is parked and all control loops are terminated. No arguments.

**DO \_ FADC** – Perform a single ADC time series. Single parameter is the number of seconds to run the series. Return values are the number of data points collected.

**DO \_ TRAN** – Parameter are the number of seconds and the amount of bump to apply. Returns the number of data points collected.

**DO \_ VTRAN** – Perform a more verbose version of the `DO_TRAN` command. Parameters are the number of seconds, followed by the amount of bump to apply. Returns the number of data points collected.

**DO \_ FAST** – Execute a faster version of the `DO_TRAN` command.

**SET \_ FAST \_ HZ** – Set the number of samples per second to be taken when the `DO_FAST` command is executed.

**DO \_ STIFF** – Perform a hardpoint stiffness test. No arguments

**GET \_ STATUS** – Request mirror cell to return current system status. No arguments. Returns a structure with all available status information.

**SET \_ MON \_ AVG** – Set the averaging value for force monitors.

**GET \_ ACTLOC** – Get an actuator location number.

**GET \_ TIME** – Takes no arguments and causes the mirror cell to return the time stamp of the last time it was rebooted, along with the current time from it’s internal clock.

**GET \_ MON** – Get force monitor data.

**GET \_ SNAP** – Get the last set of force monitor data.



**GET\_PANIC** – Request information regarding latest cell “Panic”. No arguments. Return a string, explaining the cause of the panic.

**GET\_RAPID** – Retrieve a rapid data sample.

**GET\_PSI** – Get sector air pressure monitor readings.

**GET\_HPSI** – Get hardpoint air pressure monitor readings.

**START\_SLEW** – Begin collecting slew data. Takes no parameters and returns no values.

**STOP\_SLEW** – Stop collecting slew data. No parameters and no return values.

**DO\_SLEW** – Perform “slew”. Single-parameter is the number of seconds the slew is to last. Returns data similar to DO\_TRAN command.

**CLR\_ADJ** – Discard soft force adjustment values.

**ZAP\_ADJ** – Discard both soft and hard force adjustment values.

**PUT\_AADJ** – Change actuator Z force adjustment value for a single actuator.

**PUT\_ZADJ** – Change global actuator Z force adjustment value.

**GET\_POS** – Get mirror position.

**GET\_HPLVABS** – Get absolute hardpoint LVDT readings.

**GET\_MAGIC** – Get LVDT “magic point” values.

**SET\_MAGIC** – Change LVDT “magic point” values.

**GET\_HPLV** – Get hardpoint relative LVDT readings.

**GET\_HPLC** – Get raw load cell readings from hardpoints.

**GET\_FORCE** – Get resolved load cell readings from hardpoints.

**GET\_OLCMD** – Get outer loop command vector.

**GET\_ANGLE** – Get mirror elevation angle information.

**GET\_STUFF** – Get VMON and other system status information. No parameters

**GET\_VTEMP** – Get raw voltage readings from thermal system.

**GET\_MTEMP** – Get measured temperatures from thermal system.

**GET\_TTEMP** – Get filtered temperatures from thermal system.

**GET\_ACTU** – TBD

**GET\_ACTA** – TBD

#### 4.3.1.2. Port 5801 Command Summary

**GET\_ECOUNT** – Get current error count.

**GET\_ERRORS** – Get current error count and error details.

## 5. Troubleshooting

### 5.1. Actuators

Improper functioning actuators are indicated by the software and are recorded in the error log. This error log entry indicates the actuator location number and the problem that has been detected. After diagnosing and repairing the problem a bump test should be performed on the actuator to verify that it is operating correctly. In extreme cases it may be necessary to recalibrate the unit on the test stand.

1. Actuator will not respond
  - At the servo card verify the 48VDC supply voltage is present. If not check the fuse at the sector distribution box and replace if open.
  - Verify the DC / DC converter is outputting +/- 15VDC. If the voltage is not present then verify that the output is not shorted and if not it would indicate the converter has failed.
  - At the servo card verify that a command is present. If not check the output at the DAC card in the computer and/or verify continuity in the cabling.
  - At the servo card verify that the loadcell feedback is present. If not check the loadcell connections and verify that U6 and/or U12 is functioning properly on the card.
  - Verify that the integrator lockout signal is present. If not verify the output at the computer.
  - Verify the operation of the air pressure regulators.
2. Actuator slow to respond
  - Verify that the integrator lockout signal is present on the servo card.
  - Verify the operation of the air pressure regulators
3. Actuator out of control
  - Verify that the +/- 15 VDC is present on U6 and U12.
  - Verify the operation of U6 and U12.
  - Verify the proper excitation voltage for the loadcell.
  - Verify the load cell connections at JP4 and JP5 (not used on singles).
  - Verify that the DAC command is present at the servo card. If not check the DAC output in the computer chassis.

## 5.2. Hardpoints

The hardpoints provide a force feedback to the outer loop through the hardpoint loadcell. The units also position the mirror in the cell by changing length. The length of the unit is changed by a stepper motor and drive and the length information is fed back to the computer system by an LVDT.

1. Hardpoint will not extend or retract.
  - Verify the presence of the +5 VDC and +20 VDC power supplies are present at the motor driver.
  - Verify the proper operation of the proximity limit switches and limit circuit relays. Replace if required.
  - Verify that step pulses are present at the driver on JP1-3. If not present check the cabling and the IP-Translation board.
  - Verify the presence of the enable bit signal on the driver at JP1-6. If not present check the cabling and the IP-Translation board.
  - Verify the operation of the opto U1 on the PC board at the driver and replace if necessary.
  - Verify that the motor and coupling are positively engaged.
  - If all previous checks are verified, replace the motor driver.
2. No LVDT position feedback.
  - Verify the presence of the +/- 15 VDC supplies at the LVDT demodulator board.
  - Verify the continuity of the demodulator board cabling from the LVDT.

- Verify the continuity of the cabling from the demodulator to the computer.
- Verify the Acromag 9330 ADC operation.
- If all previous checks verified replace demodulator board.

### 5.3. Thermocouples

The thermocouple monitoring system consists of 112 Type T thermocouples, an isothermal junction block (IJB) with integral multiplexer board and an AD590 current source temperature transducer for measuring the IJB temperature.

1. No temperature readings.
  - Verify that all cables are properly connected to the IJB.
  - Verify the presence of +5 VDC and +/- 15 VDC supplies are present on the Mux board.
  - Verify the presence of the address and control signals to the Mux board.
  - Verify the operation of the instrumentation amplifier on the Mux board.
  - Verify the AD590 operation.
2. Thermocouples read -999
  - This is an indication of an open thermocouple or an invalid AD590 output. Verify the connections at all locations (i.e. the Mux board, top plate D-sub connectors, miniature TC connectors, etc.) and the operation of the AD590.

### 5.4. Computer System

The computer enclosure houses the main computer, and all of the power supplies for the cell. The power supplies are monitored by the computer via the voltage monitor card and will indicate when there is a problem with any of the power supplies. The supply outputs should also be verified by a voltmeter if problems are indicated to verify the out of range condition of the power supply.

For diagnosing problems with the VME bus based boards refer to the operations manual for the respective card. For the Steward Observatory built cards refer to the appropriate schematic to assist in diagnosing problems.

### 5.5. Air Control

The air control system consists of five pressure transducers, a control board and four AC operated air solenoid valves.

1. Air is not provided to the cell
  - Verify that all interface cables are connected properly and that the green LED is lit on the control board.
  - Verify the presence of 120 VAC at the air control box.
  - Verify that air is being supplied to the main manifold.
  - Verify that the cell computer has not caused the air system to shut down due to an error somewhere else in the cell.
  - Verify the operation of all pressure transducers and / or the hardpoint pressure regulator.
  - Refer to schematic gear411a.sch to assist in diagnosing problems with the air control board.

## 6. Recommended Spare Parts List

The mirror support system is designed to provide failsafe operation in the event of a component failure. Should a device fail the system will no longer be fully functional and, depending on the nature of the failure, may prevent use of the system in the telescope. Due to this fact it is recommended to have at least one spare unit of the following parts on hand to allow timely repair of the system and minimal down time of the telescope. The list is divided into two broad categories, commercially available parts and those manufactured exclusively by Steward Observatory.

### Commercially available parts:

- Motorola MVME-167 CPU
- Acromag 9330 16 bit ADC
- Greenspring VIPC-610 IP Carrier board
- Greenspring IP-Digital48 Digital I/O module
- Greenspring IP-Unidig24 Digital I/O module
- Greenspring IP-Precision 12 bit ADC
- Vicor VI-PA22-EWW +/- 15 VDC Power Supply
- Acopian USC-150-401 +5 VDC, +/- 12 VDC Power Supply
- Acopian BFS-200-20 +20 VDC Power Supply
- American Precision CMD-40 Stepper Motor Driver
- Lucas-Schaevitz LVM-110 LVDT Demodulator
- Swagelock EB-45XF8-53BD Air Solenoid
- Belofram 962-312-00 I/P500 Air Regulator (Hardpoint Air)
- Belofram 962-312-000 T1000 (I/P500) Air Regulator (Actuators)
- Speedaire (Granger part # 1A483) filter
- Controlair DE-L-XX-UM Mod#178 Air Cylinder
- Aurora MW-3T-C3 and MM-3T-C3 Rod Ends (Hardpoint Breakaway)
- INA GT-21 Ball Decoupler Bearings

### Steward Observatory manufactured parts

- DAC card
- IP Translation Board
- Sector Distribution Card
- Cell Distribution Card
- Force Monitor Card
- Temperature Mux Card
- Single Axis Actuator Servo Card
- Dual Axis Actuator Servo Card
- Hardpoint Stepper Motor Interface Card
- Ball Decoupler Flexure MAG0160, MAG0165

## 7. Test Stand

### 7.1. General Description

The test stand provides a means for calibrating the single and dual axis force servo actuators. The unit consists of a steel structure with six integral loadcells mounted to the structure in such a manner that the three forces and three moments that the actuator can produce are measured. The stand allows for

mechanical adjustment of the actuators to minimize the non-controlled stray forces that can be potentially generated as well as for verifying the accuracy of the servo-controlled forces. It also provides a volts per pound gain for each actuator that is used in the cell control software.

#### 7.1.1. Test Stand Sign Conventions

1. +X is toward you.
2. +Y is to your right.
3. +Z is down.
4. +Mx is right hand rule about +X.
5. +My is left hand rule about +Y.
6. +Mz is left hand rule about +Z.

#### 7.1.2. Criteria

1. Force measurement accuracy is 1 part in 1200.
2. Axial force accuracy is 0.2 lbs at zenith.
3. Uncontrolled lateral forces must not exceed 1.3 lbs at zenith and 2.6 lbs when horizon pointing.
4. Moments, Mx, My and Mz must not exceed 177 in-lbs over +/-0.12 inches of travel.
5. Single-axis/single-puck limits are 106 in-lbs. After subtracting out the position effect ( $0.12 \times 300 \text{ lbs} = 36 \text{ in-lbs}$ ) we are left with 70 in-lbs as the single-axis actuator allocation and 141 in-lbs for duals (test limits are 50 and 75 in-lbs, respectively).
7. Dual-axis cross coupling (Fz, Fy) is 1.3 lbs at zenith and 2.6 lbs at horizon.

##### 7.1.2.1. Rejection Criteria Implementation

Rejection of an actuator against the criteria cited above can occur at the following steps of the calibration procedure:

##### 7.1.2.1.1. Single-axis Actuators

1. Reject if [Fx], [Fy] > 0.5 lbs when Fz is 0 or 100 lbs or [Fx], [Fy] > 0.75 lbs when Fz is +400 lbs.
2. Reject if [Mx], [My], [Mz] > 50 in-lbs when Fz = 100, 0 or +400 lbs.

##### 7.1.2.1.2. Dual-axis Actuators

1. Reject if [Fx], [Fy] > 0.5 lbs when Fz is 0 or [Fx], [Fy] > 0.75 lbs when Fz is +400 lbs.
2. Reject if [Fx], [Fy] > 0.5 lbs when Fy is 0 or [Fx], [Fy] > 1.5 lbs when Fy is +400 lbs.
3. Reject if [Mx], [My], [Mz] > 75 in-lbs when Fz = +400 lbs.

#### 7.1.2.1.3. Calibration Test

1. Reject if Fz error exceeds 61.0 lbs at Fz = 300 lbs after calibration.
2. Reject if Fz error exceeds 61.0 lbs at Fz = 300 lbs after calibration.

## 7.2. Software

### 7.2.1. Description

Two separate programs are provided for the test stand. Both programs are loaded into system memory at the time the stand is powered up and are available from command line.

The first is called calib, and is used to calibrate the test stand. It provides a set of commands that are useful for getting load cell data from the test stand in a couple of useful forms. The calibration procedure is usually done only once, when the stand is first built, to determine the gain factors for the load cells mounted on the stand and to insure that the stand is functioning properly.

The second program is the actual program for testing actuators. It is available in two different forms, depending on whether you are accessing the test stand from an X-terminal in an X-windows session or some form of VT100 terminal or terminal emulator. If using an X-terminal, the test is started with the x\_test command. If a VT100 is being used, then the command is v\_test.

### 7.2.2. Calibration

The object of the test stand calibration is to obtain the load cell values produced from a calibrated loading of the test stand and to use these values to derive the matrix used in the actuator calibration software. This matrix converts the test stand load cell values into X, Y, Z forces and moments.

The calibration of the test stand is accomplished by applying a series of known forces and moments to the interface plate. Each load vector produces a set of load cell voltages which are converted to forces. Given a minimum of six loads and corresponding force vectors, a matrix is determined that will convert an arbitrary force vector into a load vector. In this way, the telescope actuator can be mounted to the stand and its action can be precisely converted to forces and moments.

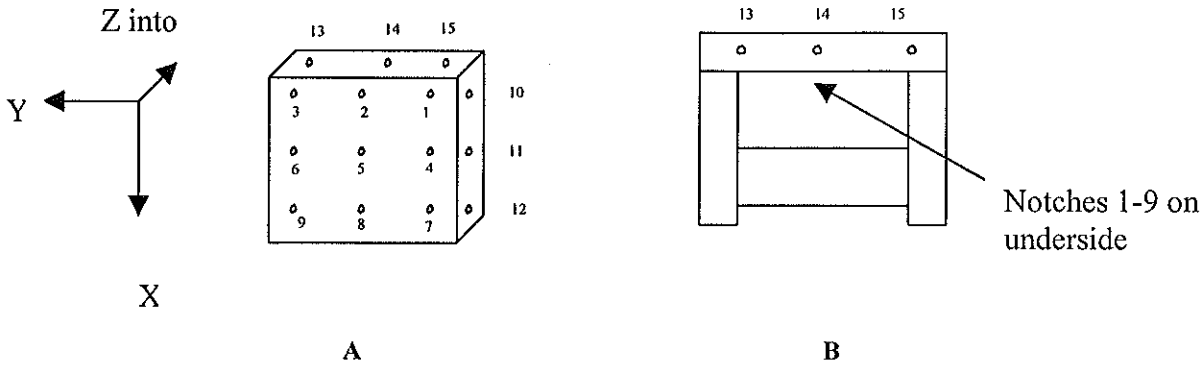

**Figure 1**  
**A. Notch designations on notch plate of reference block**  
**B. Side view of reference block**

#### 7.2.2.1 Definitions

Mathcad Program file- tstand.mcd. The program that derives the matrix requires Mathcad 2000 software.

Mathcad input files- Two files, tstand.prn and notches.prn. If using the same reference block then notches.prn remains unchanged. The tstand.prn file contains the load cell data taken at each of the reference block notches during the calibration. The tstand.mcd reads these 2 files in order to derive the matrix.

Reference block- the 6" x 8" x 9" block made out of plates screwed together containing the notches for load points in calibration. Notches 1-9 are on the underside of the main plate, notches 10-12 on one edge of the same plate and notches 13-15 on another edge of the same plate.

C-pendulum- The hook that seats into a notch on one end and attaches to the weight, chain and shackles at the other end.

Load cell and axes convention:

Matrix column	1	2	3	4	5	6
Load cell channel	0	1	2	3	4	5
Load cell number	3	4	5	6	7	8
Axis (matrix)	Z	Z	X	X	Y	Y
Axis (actuator)	Z	Z	Y	Y	X	X

Note: The matrix axes are the axes used when performing the test stand calibration. This is the axes convention that the Mathcad program uses. After the matrix is derived, and the matrix is then entered into the actuator calibration software, the Fx and Fy rows must be swapped, and the Mx and My rows must be swapped. This is the axes convention the actuator calibration software uses. For the remainder of this section the axes convention referred to is the matrix derivation axes convention.

Loading of all notches puts the corresponding load cells into tension. Refer to the figures showing the three orientations of the test stand during calibration.

Loading notches 1-9 results in +Z force.

Loading notches 10-12 results in +Y force.

Loading notches 13-15 results in a +X force.

<u>Case</u>	<u>Notches used</u>					
Case 1	1	3	8	10	12	14
Case 2	2	7	9	11	13	15
Case 3	2	6	7	11	13	15
Case 4	3	4	9	11	12	13
Forces	f1	f2	f3	f4	f5	f6

#### 7.2.2.2 Calibration Procedure

1. Hook up computer, monitor and test stand
2. Load software –readV and –setZero
3. With unloaded test stand plate, command readV
4. Check each load cell with a voltmeter. Verify the voltmeter agrees with the readV values.
5. Load test stand plate and repeat step 4, verifying that the voltmeter agrees with the readV values.
6. If the voltmeter does not agree with the readV values check the load cell amplifiers and verify that the unused inputs in the ADC inputs to the computer are grounded.
7. Apply tension and compression to each loadcell and verify that the voltage reads positive in compression and negative in tension.
8. With a precise scale weigh the calibrated weight, shackles, chain and C-pendulum.
9. Measure the notch placement relative to the test stand / actuator '0'. This means measuring all the piece parts and adding up the X, Y and Z distances from the '0' point. The '0' point is the center of the top of the test stand interface plate.
10. Attach reference block to the test stand interface plate using four long screws and an open ended wrench.
11. Use eyebolts and crane to lift and rotate test stand to desired orientation (see figures 2-4).
12. Set test stand on three metal stands and shim between the stand legs and the floor to prevent wobble in the stand.
13. Use a precision 6" long level to level the test stand, placing the level on the reference block notch plate.
14. Use wooden door shims and a mallet to achieve leveling.



15. Connect the C-pendulum to the weight using the small chain and shackles. Make sure the weight is on a small rolling jack.
16. Make sure the level and any other miscellaneous hardware has been removed from the test stand.
17. Make sure the electronics have been powered up for at least 10 minutes before taking measurements to minimize any drift in the electronics.
18. Command setZero to zero out the test stand
19. Use the small rolling jack to maneuver the weight into place.
20. Attach C-pendulum into the notch of choice for the test. Make sure that the extra chain length is piled up on top of the weight. Also make sure that the weight is not touching the metal stand legs.
21. Pull out the jack and steady the weight.
22. Re-level using the precision level, mallet and shims.
23. Steady weight.
24. Command readV. Record the displayed voltages (not the forces). Take three readings for each notch and average. Each sample also averages 20 readings.
25. Roll jack back in, lift the weight and take the C-pendulum off the test stand completely.
26. Command setZero. Make sure no hardware is still on the stand.
27. Repeat steps 20 – 26 for each notch required for the current orientation.
28. Reorient the stand in the next configuration and repeat the measurement procedure.

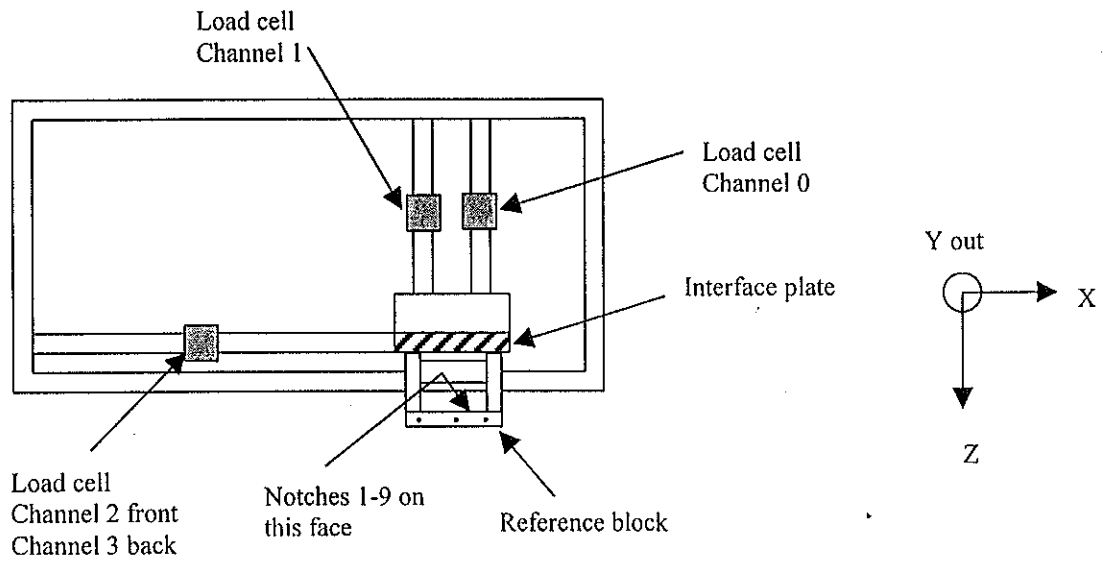

**Figure 2 (above)**  
**Orientation 1: Notches 1-9, loading +Z direction**

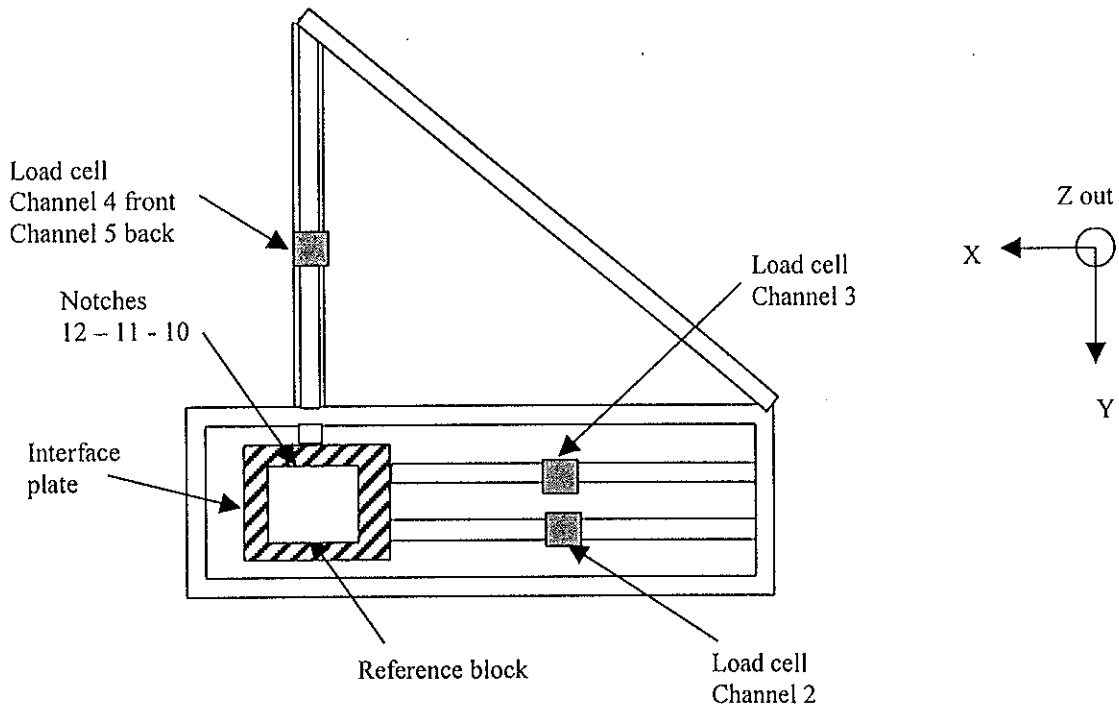

**Figure 3 (above)**  
**Orientation 2: Notches 10-12, loading +Y direction**

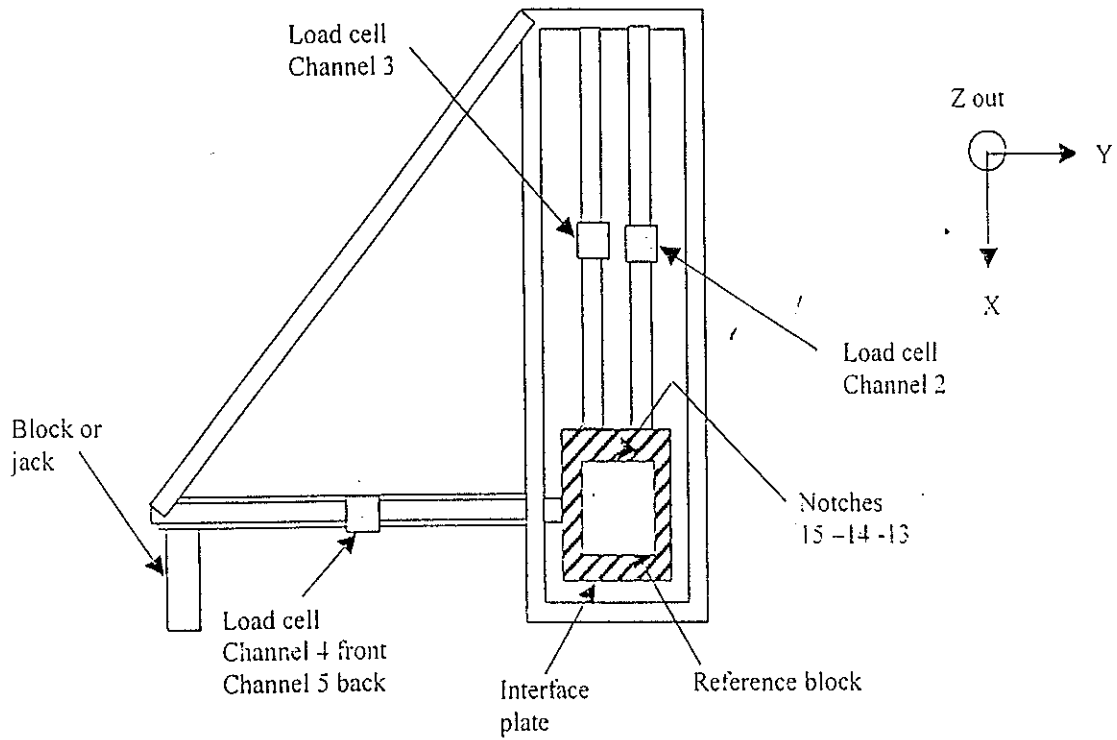

Figure 4 (above)  
 Orientation 3: Notches 13-15, loading +X direction

### 7.2.2.3 Matrix derivation procedure

1. Obtain the latest of the following Mathcad files:

- tstand.mcd
- tstand2.mcd
- tstand3.mcd
- tstand4.mcd
- tstand.prn
- notches.prn

Note: Mathcad cannot open the .prn files, use a text editor

If the .prn file is rename, then the tstand.mcd file that reads the .prn file must be edited to correspond to the change in the file name.

2. Revise the tstand.prn file to reflect the values obtained during the calibration for each notch location.
3. Revise the tstand.mcd file as follows:
  - revise the name of the .prn file being read if necessary
  - Revise the weight value if required
  - Revise xoff, yoff and zoff if required
  - If changing the set of notches being read in, revise the  $F_{1,i} = \text{force}_{1,i}$ , etc. and the  $L_{1,i} = L_{1,i}$ , etc. and rename file.
4. After having created the four tstand.mcd files corresponding to the four notch set cases, print out pages 8-9 (containing the matrix and the residual error matrix) for each file.
5. Compare the 'Resid<sup>T</sup>=' matrix of each of the four notch set cases. Highlight all values above 0.2. Note the number of values above 0.2 in each error matrix. Note the overall highest value in each error matrix.
6. Choose the best matrix based on residual error.

#### 7.2.2.4. Matrix calculations.

- What does the Mathcad file do? It creates a matrix, that when multiplied by the 6 test stand load cell readings, gives a product that is the X, Y and Z forces and moments.
- The solver works by taking the load cell readings from 6 notch locations,

(load cell readings of notches

1, 3, 8, 10, 12, 14)

$$L^3_2 = L^{\text{notch loc.}}_{\text{load cell}}$$

$$\begin{bmatrix} L^1_1 & L^1_2 & L^1_3 & L^1_4 & L^1_5 & L^1_6 \\ L^3_1 & L^3_2 & L^3_3 & L^3_4 & L^3_5 & L^3_6 \\ L^8_1 & L^8_2 & L^8_3 & L^8_4 & L^8_5 & L^8_6 \\ L^{10}_1 & L^{10}_2 & L^{10}_3 & L^{10}_4 & L^{10}_5 & L^{10}_6 \\ L^{12}_1 & L^{12}_2 & L^{12}_3 & L^{12}_4 & L^{12}_5 & L^{12}_6 \\ L^{14}_1 & L^{14}_2 & L^{14}_3 & L^{14}_4 & L^{14}_5 & L^{14}_6 \end{bmatrix}$$

X

(conversion matrix that program solves for)

$$dF_Y/dL_2 = dF_{x,y,z \text{ axis}}/dL_{\text{load cell}}$$

$$\begin{bmatrix} dF_X/dL_1 & dF_Y/dL_1 & dF_Z/dL_1 & dM_X/dL_1 & dM_Y/dL_1 & dM_Z/dL_1 \\ dF_X/dL_2 & dF_Y/dL_2 & dF_Z/dL_2 & dM_X/dL_2 & dM_Y/dL_2 & dM_Z/dL_2 \\ dF_X/dL_3 & dF_Y/dL_3 & dF_Z/dL_3 & dM_X/dL_3 & dM_Y/dL_3 & dM_Z/dL_3 \\ dF_X/dL_4 & dF_Y/dL_4 & dF_Z/dL_4 & dM_X/dL_4 & dM_Y/dL_4 & dM_Z/dL_4 \\ dF_X/dL_5 & dF_Y/dL_5 & dF_Z/dL_5 & dM_X/dL_5 & dM_Y/dL_5 & dM_Z/dL_5 \\ dF_X/dL_6 & dF_Y/dL_6 & dF_Z/dL_6 & dM_X/dL_6 & dM_Y/dL_6 & dM_Z/dL_6 \end{bmatrix}$$

(known forces and moments)

$$F^1_X = F^{\text{notch loc.}}_{x,y,z \text{ axis}}$$

$$= \begin{bmatrix} F^1_X & F^1_Y & F^1_Z & M^1_X & M^1_Y & M^1_Z \\ F^3_X & F^3_Y & F^3_Z & M^3_X & M^3_Y & M^3_Z \\ F^8_X & F^8_Y & F^8_Z & M^8_X & M^8_Y & M^8_Z \\ F^{10}_X & F^{10}_Y & F^{10}_Z & M^{10}_X & M^{10}_Y & M^{10}_Z \\ F^{12}_X & F^{12}_Y & F^{12}_Z & M^{12}_X & M^{12}_Y & M^{12}_Z \\ F^{14}_X & F^{14}_Y & F^{14}_Z & M^{14}_X & M^{14}_Y & M^{14}_Z \end{bmatrix}$$

- And by knowing what the force / moment matrix should look like (due to calibrated weights and known distances from '0' being used),
- And solves for the conversion matrix.
- Note – The matrix that the program creates has the forces and moments horizontal and load cells vertical (produces a matrix with columns/rows swapped from what is shown above). This swapped style is what the V\_test software uses, but remember to additionally swap the  $F_X$  and  $F_Y$  rows, and the  $M_X$  and  $M_Y$  rows.

#### 7.2.2.5. Revising V\_test software

1. Choose the best four matrices based on residual error.
2. Create a text file with the new matrix
3. Swap the Fx and Fy rows and the Mx and My rows.
4. Input the V\_test software
5. Print out and double check the matrix
6. Check the volts to pounds (force) conversion factor in the V\_test software. Note: the value is positive in this software, and negative in the Mathcad program, so that Fz is positive when the load cell is in compression.

#### 7.2.2.6. Testing matrix prior to actuator calibration

1. Remove test stand from metal stands and rotate upright.
2. Re-install leveling feet
3. Remove reference block
4. Level stand using precision level on interface plate.
5. Remove level and any hardware from stand.
6. Allow electronics to be powered up for at least 10 minutes.
7. Command setZero
8. Load top of interface plate, in the center, with two 50 lb. weights.
9. Command readV
10. Record the 6 load cell readings and multiply them by the matrix to produce the forces and moments. The results should be similar to: 0.01 -0.03 100.2 3.1 -4.2 0.3.
11. If values are not similar a problem occurred in the calibration, otherwise proceed.
12. Remove weights.
13. Load V\_test software.
14. Command 'z' to zero the test stand.
15. Check to verify that the real time forces and moments are reading near zero.
16. Re-load the two 50 lb. Weights in the center of the interface plate.
17. Check the real time forces and moments to verify that they agree with the values obtained from multiplying the load cell values by the matrix. The results should be similar to: -0.05 0.01 100.17 -2.8 -1.1 -0.8.

#### 7.2.3. Testing

The test program is started by entering the command x\_test (or v\_test, depending on the interface being used) at the command line of the terminal or window being used. After a slight delay, the program will put the terminal in a "full-screen" mode, with dynamically updating data fields, showing several pieces of information about the current status of the test stand and any actuator attached to it.

#### 7.2.4. Test Data

The software to analyze the test data consists of a set of gnuplot functions to process the raw data and produce plots of forces and moments, either on the screen or to a postscript file that can be printed.

YwavePlot - process the y-Wave test data and produces two graphs: y-error and z-error values over time and moments in x, y and z over time.

ZwavePlot - produces the same types of plots as described for YwavePlot, but uses z-Wave test data as input.

TMagPlot – uses the transient test data as input and produces a graph of forces in the z and y axis over time.

### 7.3. Test Procedures

#### 7.3.1 Single-axis Actuator Test Procedures

##### 7.3.1.1. Overview

1. Zero out test stand (z)
2. Install actuator
3. Perform bump test (sz load)
4. Perform initial auto-calibration test (c)
5. Perform initial wave test (w)
6. 8 minute burn-out
7. During burn-in, adjust the actuator air cylinder
8. Auto-calibrate (c)
9. Perform wave test (w)
10. Perform transient test (t)

##### 7.3.1.2. Detailed Procedures

1. Turn on power strip. AC power, +30V, +/-15V for LC Rs, terminal and crate power (crate should be switched on).
2. After the crate boots, enter v\_test.
3. Type as (for single-axis actuator).
4. Set air pressure to 130psi (125 to 150psi).
5. Install the single-axis actuator interface hardware, the actuator mounting plate and the load cell interface member.
6. Type z to zero out the test stand (remove the trans torque before zeroing). When testing multiple single-axis actuators, this step is the starting point for all subsequent actuators.
7. Install the actuator using the appropriate adapter plug.
8. Hook up air.
9. Check “test stand” forces.
  - Mx, My and Mz must be less than 100 in-lbs.
  - Fx and Fy must be less than 5 lbs.
  - Fz must be -100 to +100 lbs.
10. Type J to enable the integrator (close the force loop). Check forces – they should be somewhere close to zero.

11. Check "test stand" forces.
  - Mx, My and Mz must be less than 100 in-lbs.
  - Fx and Fy must be less than 5 lbs.
  - Fz must be -5 to +5 lbs.
12. Bump test both directions.
 

sz 400	Fz = 395 to 405	test stand = 350 to 450
sz 0	Fz = -5 to 5	test stand = -5 to 5
sz -400	Fz = -405 to -395	test stand = -450 to -350
sz 0	Fz = -5 to 5	test stand = -5 to 5
13. Type c to perform an initial auto-calibration test.
14. When prompted, enter Filename = pcmag1-sna where 'sn' is the actuator serial number and 'a' is a test sequence number. (If this actuator is retested, use b, etc.). Example: pcmag1-03a
15. When prompted for serial number, enter the actuator's serial number.
16. Type 'w' to perform a wave test (z direction).
17. When prompted for wave test direction, enter 'z'.
18. Using a convention similar to the one for Filename given above, enter the Filename in the format: wmag1-z-sna, where 'sn' again is the actuator serial number and 'a' is the test sequence. Example: wmag1-z-003a
19. Type 't' to perform the transient test.
20. For the direction, enter 'z' when prompted.
21. Enter a testing time of 4.
22. Enter 20 for starting force.
23. For ending force, enter -20.
24. Set the Other axis force to 0.
25. Enter the Filename as tmag1-z-sna, using the conventions discussed for filenames earlier. Example: tmag1-z-032a
26. Pull off the airline and remove the actuator.
27. Test complete.

### 7.3.2. Dual-axis Actuator Test Procedure

#### 7.3.2.1. Overview

1. Zero out test stand (z)
2. Install actuator
3. Perform bump test (sz load)
4. Perform initial auto-calibration test (c)
5. Perform initial wave test, z axis (w)
6. Perform initial wave test, y axis (w)
7. 8 minute burn-in
8. During burn-in, adjust the actuator air cylinder
9. Auto-calibrate (c)
10. Perform wave test, z axis (w)



11. Perform wave test, y axis (w)
12. Perform transient test, z axis (t)
13. Perform transient test, y axis (t)

### 7.3.2.2. Detailed Procedure

1. Turn on power strip. AC power, +30V, +/-15V for LC Rs, terminal and crate power (crate should be switched on).
2. After the crate boots, enter v\_test.
3. Type 'ad' (for dual-axis actuator).
4. Set air pressure to 130psi (125 to 150psi).
5. Install the dual-axis actuator interface hardware, the actuator mounting plate and the load cell interface member.
6. Type 'k' to disable the integrator.
7. Type 'z' to zero out the test stand.
8. Install the actuator.
9. Hook up air.
10. Check "test stand" forces.
  - Mx, My and Mz must be less than 100 in-lbs.
  - Fx and Fy must be less than 5 lbs.
  - Fz must be -100 to +100 lbs.
11. Type 'J' to enable the integrator (close the force loop). Check forces. They should be somewhere close to zero.
12. Check "test stand" forces.
  - Mx, My and Mz must be less than 100 in-lbs.
  - Fx and Fy must be less than 5 lbs.
  - Fz must be -5 to 5 lbs.
13. Bump test both directions:
 

sz 400	Fz = 395 to 405	Fy = -5 to 5
test stand:	Fz = 350 to 450	Fy = -5 to 5
sz -400	Fz = -405 to -395	Fy = -5 to 5
test stand:	Fz = -450 to -350	Fy = -5 to 5
sz 0	Fz = -5 to 5	Fy = -5 to 5
test stand:	Fz = -5 to 5	Fy = -5 to 5
sy 400	Fz = -5 to 5	Fy = 395 to 450
test stand:	Fz = -5 to 5	Fy = 395 to 450
sy -400	Fz = -5 to 5	Fy = -405 to -395
test stand:	Fz = -5 to 5	Fy = -405 to -395
sy 0	Fz = -5 to 5	Fy = -5 to 5
test stand:	Fz = -5 to 5	Fy = -5 to 5

#### Notes:

S1 400 is the same as 'sz' 400.

S2 400 exercises only the diagonal cylinder, 'sy' 400 commands a 'y' force of 400.

14. Type 'c' to perform an initial auto-calibration test.
  - Filename = pc-mag1-sna
  - Serial # = the serial number of the actuator being tested
15. Type 'w' to perform the wave test (z direction).
  - Direction = z
  - Filename = pz-wmag1-sna, where 'sn' is the actuator serial number and 'a' is a test sequence letter (if this actuator is re-tested, use 'b', etc.)
16. Type 'w' to perform
  - Direction = y Note: 2 results in only diagonal cylinder being exercised
  - Filename = py-wmag1-sna, where 'sn' is the actuator serial number and 'a' is a test sequence letter. (If this actuator is re-tested, use 'b', etc.). Examples: py-wmag1-103a for the first test of actuator 103, py-wmag1-103b if this actuator is reworked and re-tested. Note that the test program will not allow a file to be overwritten.
17. Type 'w' to perform the wave test (y direction).
  - Direction = y Note: 2 results in only diagonal cylinder being exercised.
  - Filename = py-wmag1-sna, where 'sn' is the actuator serial number and 'a' is a test sequence letter. (If this actuator is re-tested, use 'b', etc.). Examples: py-wmag1-103a for the first test of actuator 103, py-wmag1-103b if this actuator is reworked or re-tested. Note that the test program will not allow a file to be overwritten.
18. Burn-in and adjustment (at least 8 minutes of operation including adjustment time). Note that 2 minutes of the required 10-minute burn-in are taken up by the wave test.
19. Air Cylinder Adjustment
  1. Apply a 400 lb axial load sz 400.
  2. Adjust the tilt of the axial air cylinder to reduce Fx and Fy to less than 0.5 lbs (-0.5 to 0.5).
  3. Apply a -100 lb axial load sz -100.
  4. Verify that the magnitude of Fx and Fy are less than 0.75 lbs.
  5. Zero out the axial load (sz 0) and verify that Fx and Fy are less than 0.5 lbs.
  6. If the above requirements are not satisfied, adjust until the magnitude of Fx and Fy are less than +/-0.5 lbs under zero and less than +/-0.75 for +/-400 lbs axial. Fail the actuator if this cannot be achieved.
  7. Zero out the axial force (sz 0) and apply a -400 lb commanded lateral load to actuators 54 to 86 or a 400 lb commanded lateral load to actuators 87 to 105 (sy -400 or sy 400).
  8. Adjust the tilt of the diagonal air cylinder to reduce Fx and Fz to less than 0.5 lbs (-0.5 to +0.5)
  9. Zero out the lateral load (sy 0) and verify that Fx and Fz are less than 0.5 lbs.

10. If these requirements are not satisfied, adjust until the magnitude of  $F_x$  and  $F_z$  are less than  $\pm 0.5$  lbs under zero and less than  $\pm 1.5$  for  $\pm 400$  lbs lateral. Fail the actuator if this cannot be achieved.
11. Check  $M_x$ ,  $M_y$  and  $M_z$  at  $-100$ ,  $0$  and  $+400$  lbs axial load. None of these forces can be permitted to exceed  $\pm 70$  in-lbs. Reject the actuator if this condition is not satisfied.
12. Check  $M_x$ ,  $M_y$  and  $M_z$  at  $-400$  or  $+400$  lbs axial load. None of these forces can be permitted to exceed  $\pm 70$  in-lbs. Reject the actuator if this condition is not satisfied.

Note: When changing from axial to lateral loading, or vice versa, zero out the initial load before applying the new load. For example, to go from an axial load of 600 lbs to a 400-lb lateral load, type 'sz 0' then 'sy 400'.

#### 7.4. Troubleshooting the Test Stand

The software for the test stand, unless modified, should perform as described in this section. If anomalous results occur it is probably due to a hardware failure with the test stand electronics or computer system, or with the actuator being tested. The following areas should be investigated when problems do occur.

- If an actuator does not respond to a commanded force, check the "Readback" field of the test stand interface. If it is reasonable for the force commanded, the commanded voltage may not be getting to the actuator. This can be checked with a voltmeter on the test stand. If the expected voltage is present at the connector, then the actuator or its associated control card will need to be diagnosed.
- If a loadcell seems to be reading abnormally low, given the commanded force, this should also be checked with a voltmeter at the output of the preamplifier.
- Strange readings on the actuator may be the result of the stand being set for a dual actuator when it is testing a single actuator or vice versa.
- Whenever problems are encountered when testing an actuator always verify that the actuator is working correctly before investigating the test stand.

Appendix A  
Electronic Schematics

COMPUTER INTERFACE PLATE

OUTSIDE CELL

INSIDE CELL

HARDPOINT #0

TYPICAL 3 PLACES

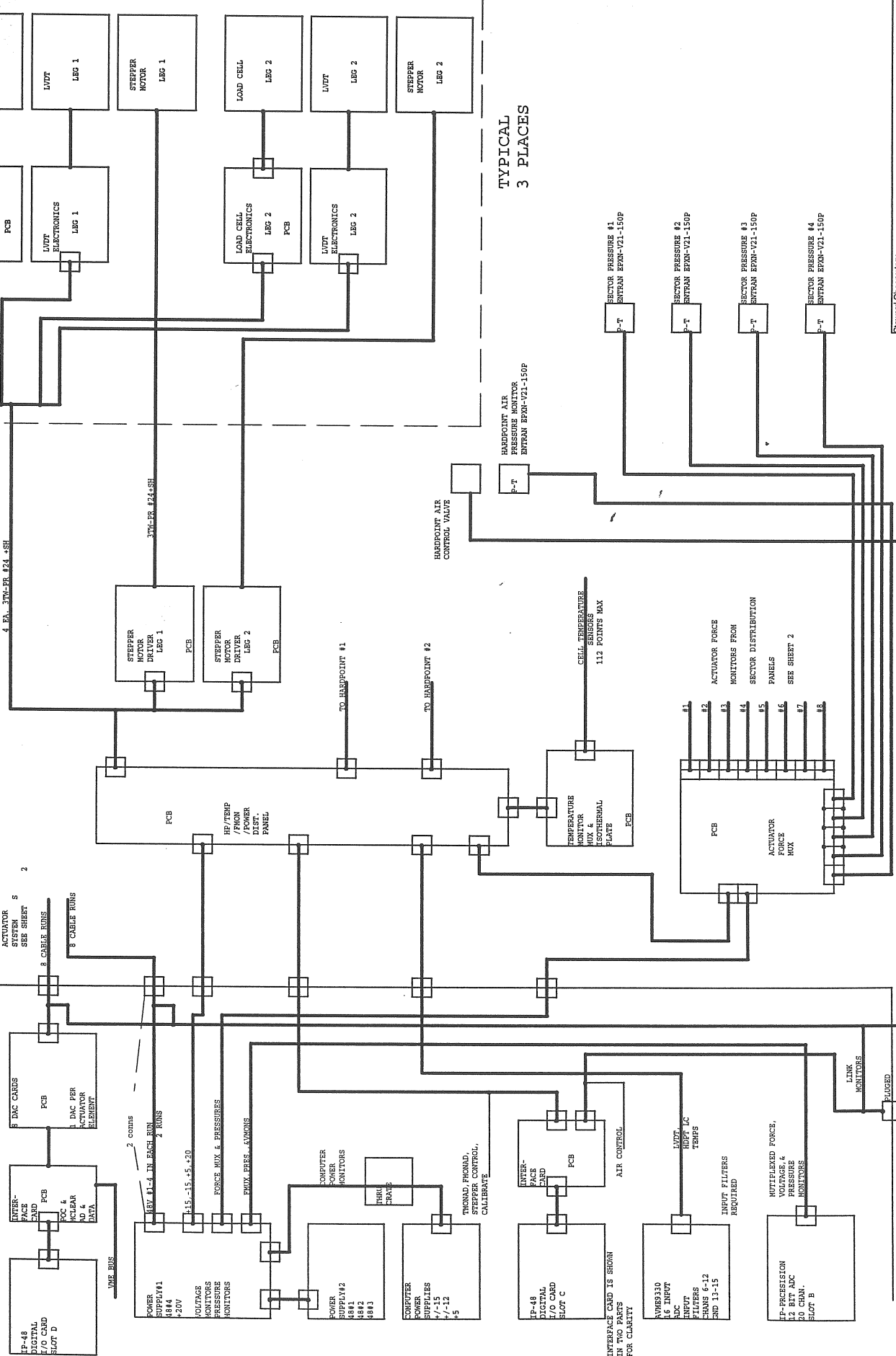

Title		SYSTEM BLOC K1	
Size	B	Document Number	MAG1CELL: Gesy006.SCH
Date	Friday, October 28, 1989	Sheet	1 of 2

Steward Observatory

LINK MONITORING  
IS DONE AT EACH  
INPUT CONNECTOR  
ON ALL SECTOR PLATES

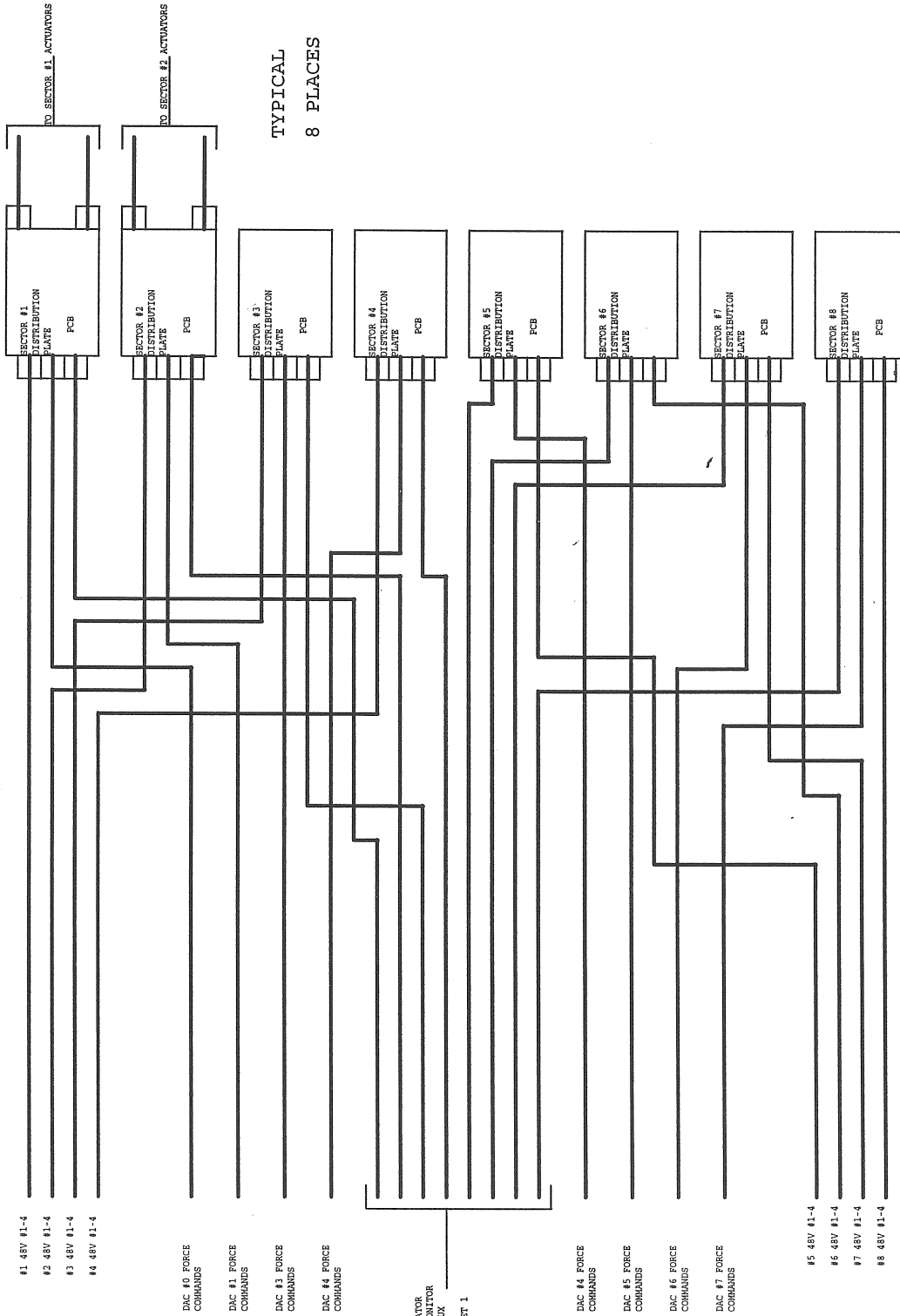

LINKS ARE MONITORED  
AT BOTH ENDS

INTEL#1-4 AND  
LINK MONITOR  
CABLE COMMAND

Steward Observatory

Title SYSTEM BLOC K2

Size B Document Number  
MAGICELL: Gesy001a.SCH

Date: Monday, September 27, 1989

Sheet 2 of 2

1 2 3 4 5 6 7 8

OUTSIDE CELL

INSIDE CELL  
RIGHT SIDE

INSIDE CELL  
LEFT SIDE

DISCONNECTS  
MOUNTED IN COMPUTER  
ENCLOSURE  
REQUIRES KEY ENTRY

12 BIT  
ADC

8 DAC'S  
13 CHAN. EACH

2 EA.  
RED  
YEL  
GRN  
BLU

4 EA.  
48VDC  
POWER  
SUPPLIES

SECTOR 1 FORCES  
SECTOR 2 FORCES  
SECTOR 3 FORCES  
SECTOR 4 FORCES  
SECTOR 5 FORCES  
SECTOR 7 FORCES  
SECTOR 8 FORCES

FORCE  
MONITOR  
MUX

DISP.  
PANEL

FORCE  
COMMANDS  
AND  
POWER

R-O-Y-B  
PWR. & SIGNAL

R-O-Y-B PWR. & SIGNAL

R-O-Y-B PWR. & SIGNAL

R-O-Y-B  
PWR. & SIGNAL

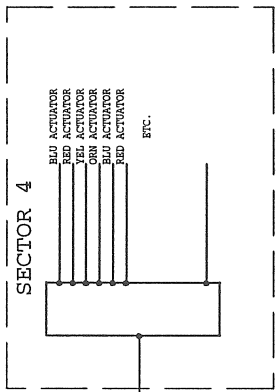
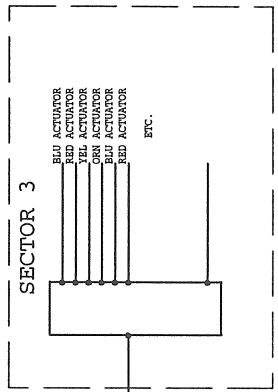
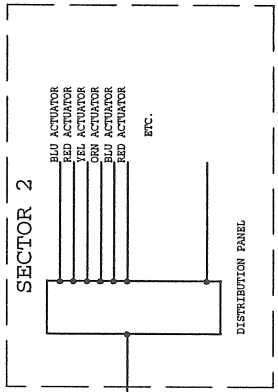
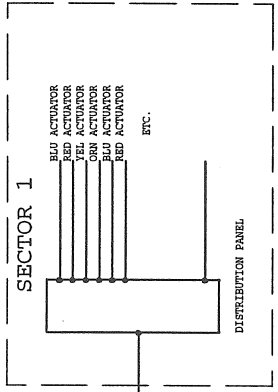

STEWART OBSERVAT ORY  
UNIVERSITY OF ARIZONA

Title  
CABLE DIAGRA M

Size  
B

Document Number  
MAGICELL: Gesy811a.sch

Date: Monday, September 27, 1989

Rev  
A

Sheet  
1 of 1

3 4 5 6 7 8





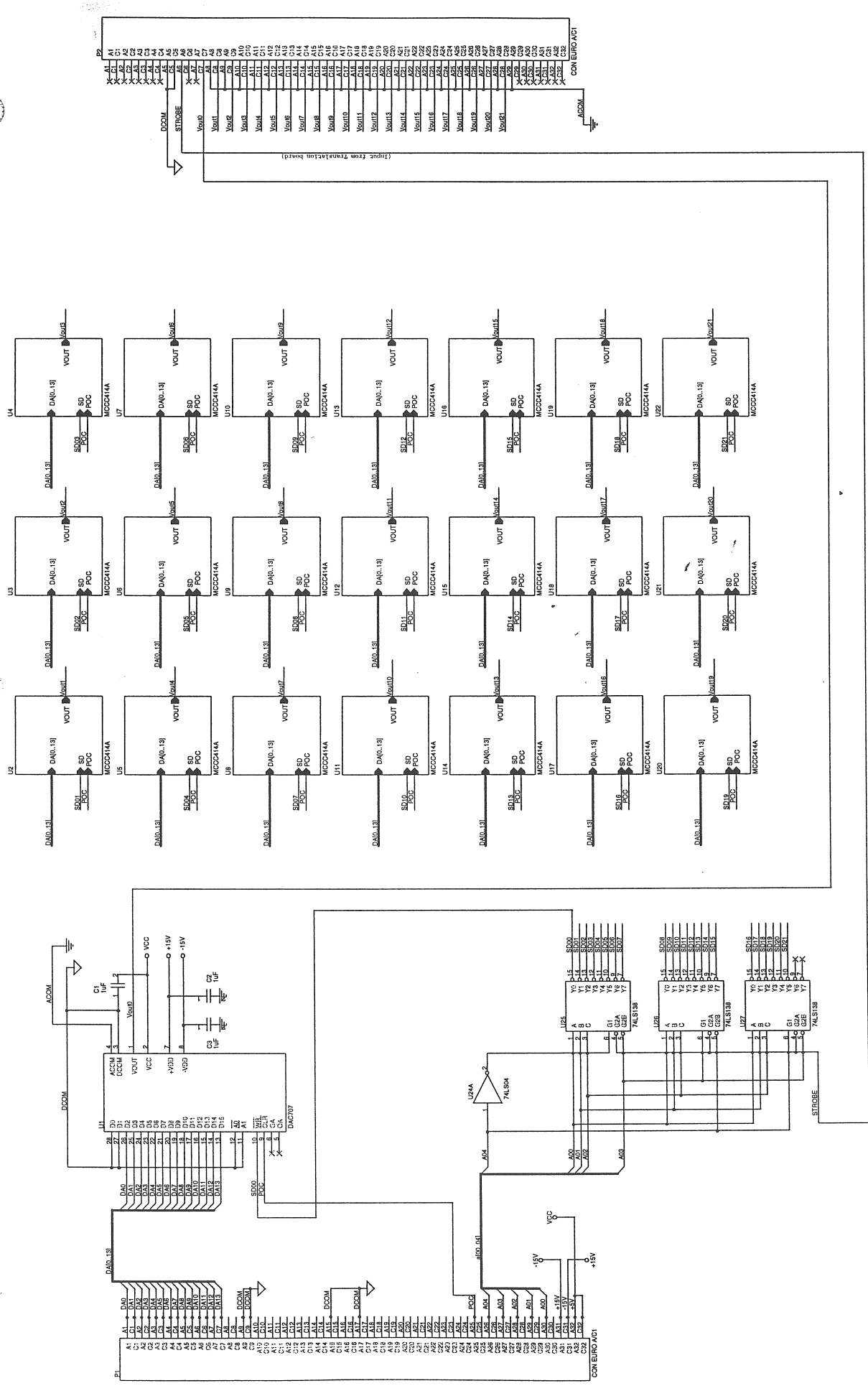

STEWARD OBSERVER/RECORD 157 Input gain error  
 UNIVERSITY OF ARIZONA  
 JANSSEN V2.027A  
 File VME DAC707 CARD (revised mcccc111.a.sp)  
 Sheet Count Number  
 C MAGICELL: Gcc-413a.sp  
 Date: Monday, September 27, 1993 8:38:08 AM  
 Row A

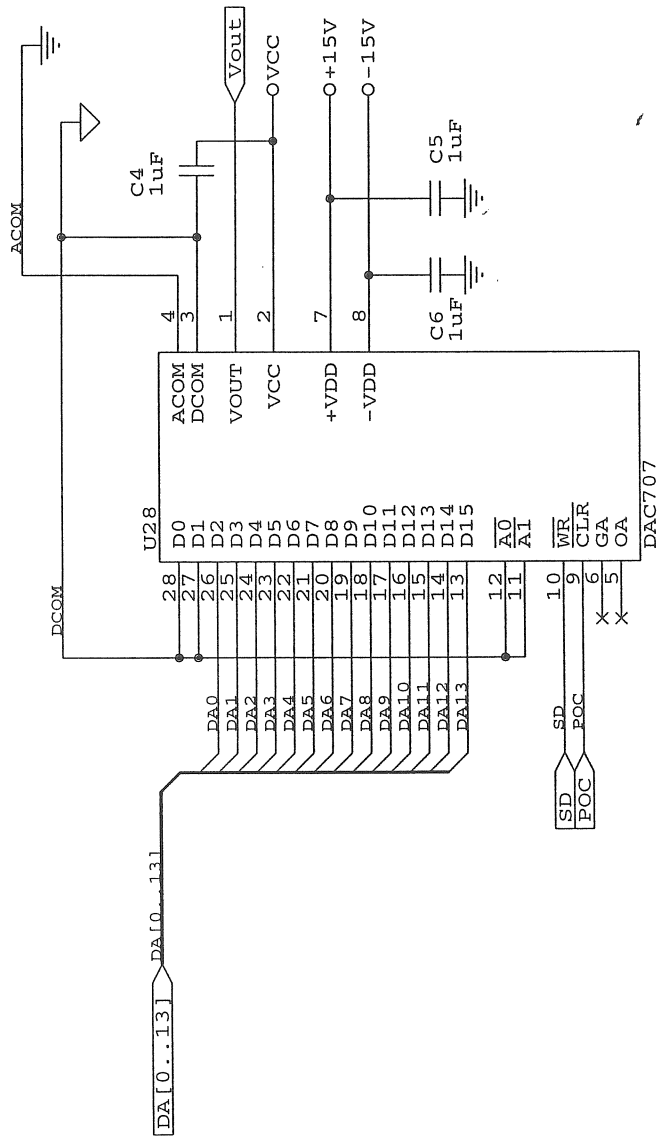

LIBRARIES:  
ken  
pcbbdev

Title		VME DAC707 CARD
Size	Document Number	REV
A	MAGCELL: gcc414a.sch	A
Date:	May 5, 1999	Sheet 2 of 2





KPSB06F-18-11S

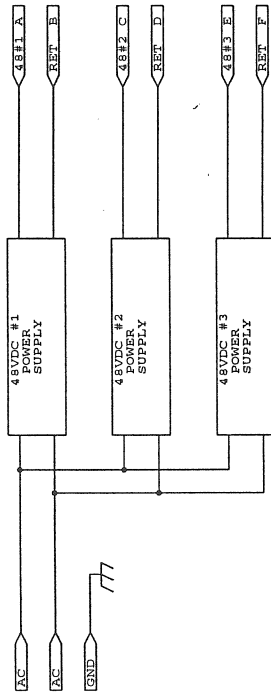

STEWART OBSERVATORY

Title	POWER SUPPLY CHASSIS #2
Size	Document Number
REV	B
Date	JANUARY 27, 2000
Sheet	1 of 1

TRANSLATION CARD

TO DAC CARDS

P2

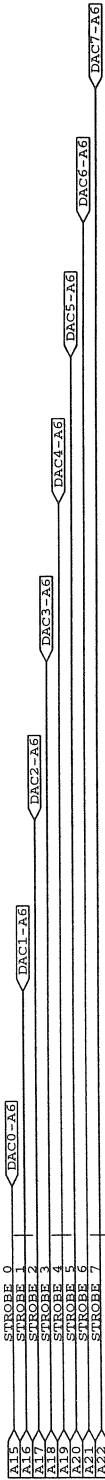

TRANSLATION CARD

ALL DAC CARDS

P1

P1

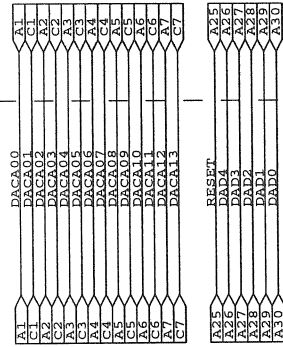

FROM  
COMPUTER  
POWER  
SUPPLIES

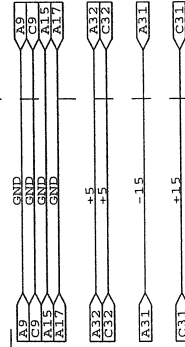

# COMPUTER DISCONNECT PANEL

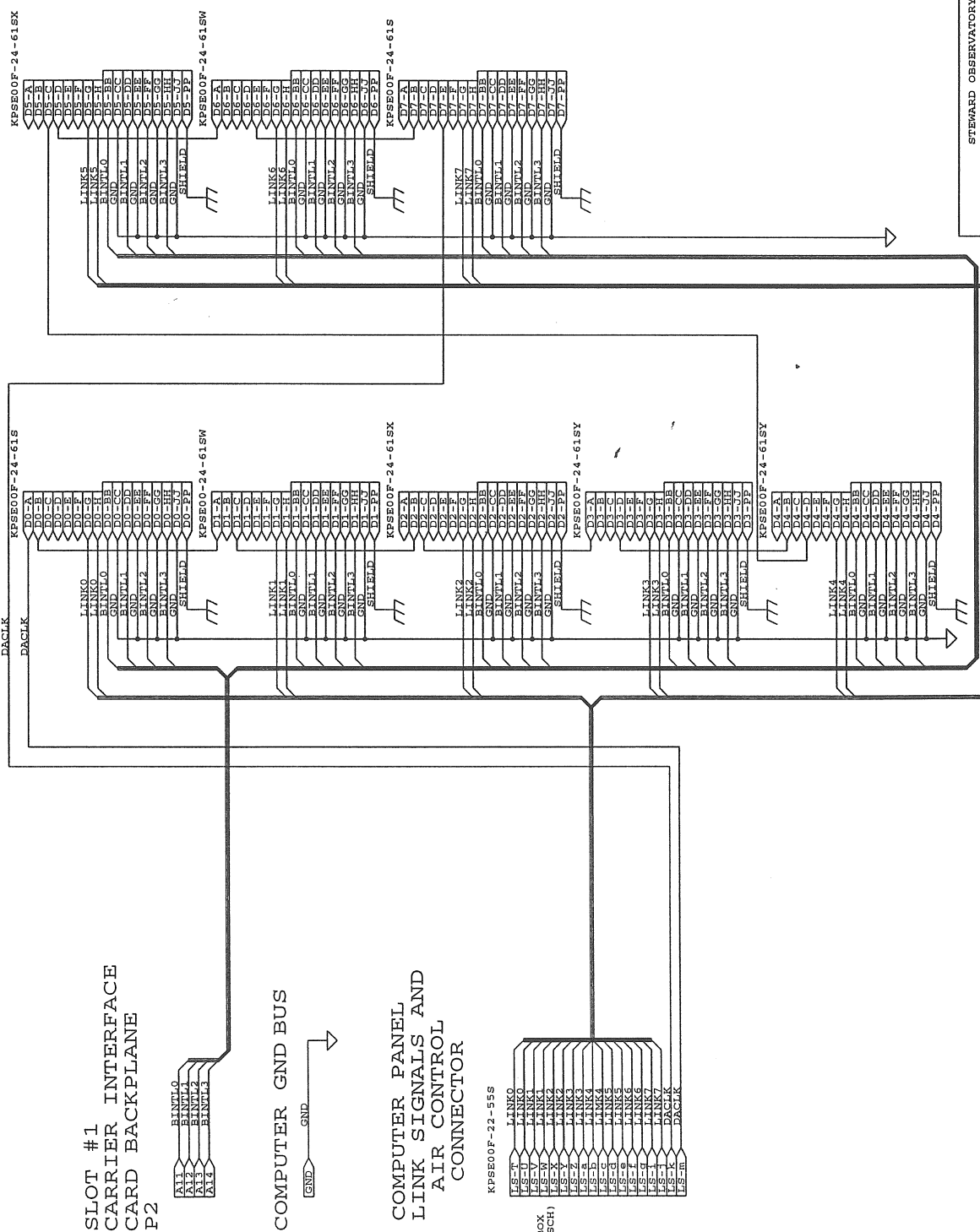

STEWART OBSERVATORY  
UNIVERSITY OF ARIZONA

Title  
COMPUTER BOX CABLING - WIREL

Size  
B Document Number: gccc812b.sch  
A MAGCELL: gccc812b.sch

REV  
A

Date: January 27, 2000 Sheet 1 of 5

FROM AIR CONTROL BOX  
DRAWING # (gcar11a.sch)

KPSE00F-22-55S  
U5-T LINK0  
U5-V LINK1  
U5-W LINK2  
U5-X LINK3  
U5-Y LINK4  
U5-Z LINK5  
U5-A LINK6  
U5-B LINK7  
U5-C LINK8  
U5-D LINK9  
U5-E LINK10  
U5-F LINK11  
U5-G LINK12  
U5-H LINK13  
U5-I LINK14  
U5-J LINK15  
U5-K DACLK  
U5-L DACLK  
U5-M

COMPUTER  
DICONNECT  
PANEL

COMPUTER  
DICONNECT  
PANEL

**COMPUTER DICONNECT PANEL**

**DAC#0 SLOT 2 BLUE**

P2-C7	DAC 0+	D0-J	51
P2-A7	DAC 0-	D0-K	49
P2-C8	DAC 1+	D0-L	48
P2-A8	DAC 1-	D0-M	47
P2-C9		D0-N	46
P2-A9		D0-O	45A
P2-C10		D0-P	45B
P2-A10		D0-Q	44
P2-C11		D0-R	43
P2-A11		D0-S	35A
P2-C12		D0-T	35B
P2-A12		D0-U	37A
P2-C13		D0-V	37B
P2-A13		D0-W	28A
P2-C14		D0-X	28B
P2-A14		D0-Y	26A
P2-C15		D0-Z	26B
P2-A15		D1-A	18A
P2-C16		D1-B	18B
P2-A16		D1-C	16A
P2-C17		D1-D	16B
P2-A17		D1-E	9A
P2-C18		D1-F	9B
P2-A18		D1-G	7
P2-C19		D1-H	6
P2-A19		D1-I	2
P2-C20		D1-J	
P2-A20		D1-K	
P2-C21		D1-L	
P2-A21		D1-M	
P2-C22		D1-N	
P2-A22		D1-O	
P2-C23		D1-P	
P2-A23		D1-Q	
P2-C24		D1-R	
P2-A24		D1-S	
P2-C25		D1-T	
P2-A25		D1-U	
P2-C26		D1-V	
P2-A26		D1-W	
P2-C27		D1-X	
P2-A27		D1-Y	
P2-C28		D1-Z	
P2-A28		D2-A	

**DAC#2 SLOT 4 RED**

P2-C7	DAC 0+	D0-L	52
P2-A7	DAC 0-	D0-M	46
P2-C8	DAC 1+	D0-N	44A
P2-A8	DAC 1-	D0-O	44B
P2-C9		D0-P	34
P2-A9		D0-Q	38
P2-C10		D0-R	36A
P2-A10		D0-S	36B
P2-C11		D0-T	27A
P2-A11		D0-U	27B
P2-C12		D0-V	25
P2-A12		D0-W	19
P2-C13		D0-X	17A
P2-A13		D0-Y	17B
P2-C14		D0-Z	10
P2-A14		D1-A	15
P2-C15		D1-B	8A
P2-A15		D1-C	8B
P2-C16		D1-D	3
P2-A16		D1-E	
P2-C17		D1-F	
P2-A17		D1-G	
P2-C18		D1-H	
P2-A18		D1-I	
P2-C19		D1-J	
P2-A19		D1-K	
P2-C20		D1-L	
P2-A20		D1-M	
P2-C21		D1-N	
P2-A21		D1-O	
P2-C22		D1-P	
P2-A22		D1-Q	
P2-C23		D1-R	
P2-A23		D1-S	
P2-C24		D1-T	
P2-A24		D1-U	
P2-C25		D1-V	
P2-A25		D1-W	
P2-C26		D1-X	
P2-A26		D1-Y	
P2-C27		D1-Z	
P2-A27		D2-A	
P2-C28		D2-B	
P2-A28		D2-C	

ACTUATOR NUMBERS  
ARE SHOWN NEXT TO  
DISCONNECT PANEL  
CONNECTOR PIN  
ASSIGNMENTS

COMPUTER  
DICONNECT  
PANEL

COMPUTER  
DICONNECT  
PANEL

**COMPUTER DICONNECT PANEL**

**DAC#1 SLOT 3 ORANGE**

P2-C7	DAC 0+	D0-Z	50
P2-A7	DAC 0-	D0-A	48
P2-C8	DAC 1+	D0-B	39A
P2-A8	DAC 1-	D0-C	39B
P2-C9		D0-D	41A
P2-A9		D0-E	41B
P2-C10		D0-F	32A
P2-A10		D0-G	32B
P2-C11		D0-H	30A
P2-A11		D0-I	30B
P2-C12		D0-J	24
P2-A12		D0-K	22A
P2-C13		D0-L	22B
P2-A13		D0-M	14A
P2-C14		D0-N	14B
P2-A14		D0-O	20
P2-C15		D0-P	12A
P2-A15		D0-Q	12B
P2-C16		D0-R	4
P2-A16		D0-S	
P2-C17		D0-T	
P2-A17		D0-U	
P2-C18		D0-V	
P2-A18		D0-W	
P2-C19		D0-X	
P2-A19		D0-Y	
P2-C20		D0-Z	
P2-A20		D1-A	
P2-C21		D1-B	
P2-A21		D1-C	
P2-C22		D1-D	
P2-A22		D1-E	
P2-C23		D1-F	
P2-A23		D1-G	
P2-C24		D1-H	
P2-A24		D1-I	
P2-C25		D1-J	
P2-A25		D1-K	
P2-C26		D1-L	
P2-A26		D1-M	
P2-C27		D1-N	
P2-A27		D1-O	
P2-C28		D1-P	
P2-A28		D1-Q	

**DAC#3 SLOT 5 YELLOW**

P2-C7	DAC 0+	D0-E	47
P2-A7	DAC 0-	D0-F	40A
P2-C8	DAC 1+	D0-G	40B
P2-A8	DAC 1-	D0-H	42A
P2-C9		D0-I	42B
P2-A9		D0-J	33
P2-C10		D0-K	31A
P2-A10		D0-L	31B
P2-C11		D0-M	23A
P2-A11		D0-N	23B
P2-C12		D0-O	21A
P2-A12		D0-P	21B
P2-C13		D0-Q	13A
P2-A13		D0-R	13B
P2-C14		D0-S	11A
P2-A14		D0-T	11B
P2-C15		D0-U	5
P2-A15		D0-V	1
P2-C16		D0-W	
P2-A16		D0-X	
P2-C17		D0-Y	
P2-A17		D0-Z	
P2-C18		D1-A	
P2-A18		D1-B	
P2-C19		D1-C	
P2-A19		D1-D	
P2-C20		D1-E	
P2-A20		D1-F	
P2-C21		D1-G	
P2-A21		D1-H	
P2-C22		D1-I	
P2-A22		D1-J	
P2-C23		D1-K	
P2-A23		D1-L	
P2-C24		D1-M	
P2-A24		D1-N	
P2-C25		D1-O	
P2-A25		D1-P	
P2-C26		D1-Q	
P2-A26		D1-R	
P2-C27		D1-S	
P2-A27		D1-T	
P2-C28		D1-U	
P2-A28		D1-V	
P2-C29		D1-W	
P2-A29		D1-X	
P2-C30		D1-Y	
P2-A30		D1-Z	
P2-C31		D2-A	
P2-A31		D2-B	
P2-C32		D2-C	
P2-A32		D2-D	
P2-C33		D2-E	
P2-A33		D2-F	
P2-C34		D2-G	
P2-A34		D2-H	
P2-C35		D2-I	
P2-A35		D2-J	
P2-C36		D2-K	
P2-A36		D2-L	
P2-C37		D2-M	
P2-A37		D2-N	
P2-C38		D2-O	
P2-A38		D2-P	

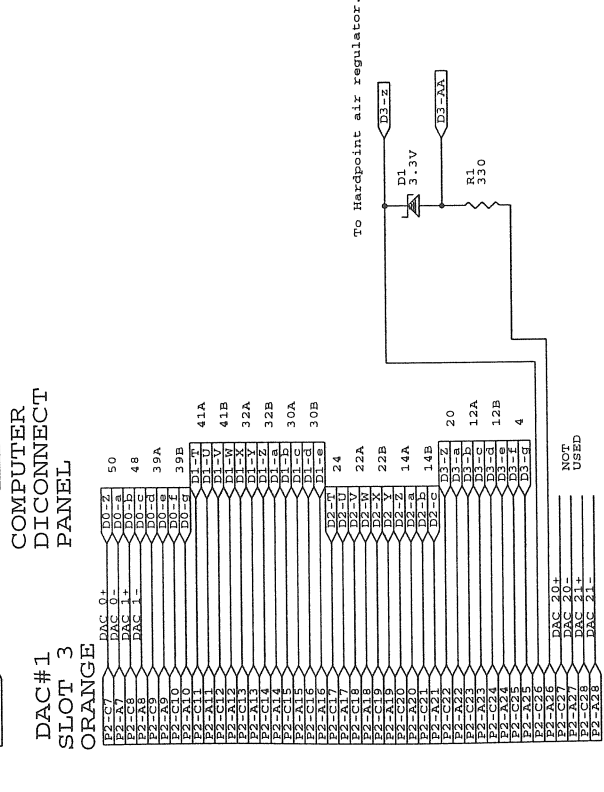



COMPUTER  
DICONNECT  
PANEL  
DAC #4  
SLOT 6  
BLUE

P2-C7	DAC 0+	D7-V	151
P2-A7	DAC 1+	D7-K	149
P2-S8	DAC 1-	D7-M	145A
P2-C9	D7-P	D7-N	145A
P2-A9	D7-R	D7-S	145B
P2-C10	D7-T	D7-U	143
P2-A11	D7-V	D7-W	135A
P2-S12	D7-X	D7-Y	135B
P2-C13	D6-V	D6-W	137A
P2-A14	D6-X	D6-Y	137B
P2-S15	D6-Z	D6-AA	128A
P2-C16	D6-AB	D6-AC	128B
P2-A17	D6-AD	D6-AE	126A
P2-S18	D6-AF	D6-AG	126B
P2-C19	D6-AH	D6-AI	118A
P2-A20	D6-AJ	D6-AK	118B
P2-S21	D6-AL	D6-AM	116A
P2-C22	D6-AN	D6-AO	116B
P2-A23	D6-AP	D6-AQ	19A
P2-S24	D6-AR	D6-AS	19B
P2-C25	D6-AT	D6-AU	17
P2-A26	D6-AV	D6-AW	16
P2-S27	D6-AX	D6-AY	12
P2-C28	DAC 20+	D6-AZ	
P2-A29	DAC 20-	D6-BA	
P2-S30	DAC 21+	D6-BC	
P2-C31	DAC 21-	D6-BD	

KPSE00F-24-61S

KPSE00FF-24-61SW

KPSE00F-24-61SX

KPSE00F-24-61SY

COMPUTER  
DICONNECT  
PANEL  
DAC #6  
SLOT 8  
RED

P2-C7	DAC 0+	D7-V	152
P2-A7	DAC 1+	D7-K	146
P2-S8	DAC 1-	D7-M	144A
P2-C9	D7-P	D7-N	144A
P2-A9	D7-R	D7-S	144B
P2-C10	D7-T	D7-U	134
P2-A11	D7-V	D7-W	138
P2-S12	D7-X	D7-Y	136A
P2-C13	D6-V	D6-W	136B
P2-A14	D6-X	D6-Y	127A
P2-S15	D6-Z	D6-AA	127B
P2-C16	D6-AB	D6-AC	125
P2-A17	D6-AD	D6-AE	119
P2-S18	D6-AF	D6-AG	117A
P2-C19	D6-AH	D6-AI	117B
P2-A20	D6-AJ	D6-AK	110
P2-S21	D6-AL	D6-AM	115
P2-C22	D6-AN	D6-AO	18A
P2-A23	D6-AP	D6-AQ	18B
P2-S24	D6-AR	D6-AS	13
P2-C25	D6-AT	D6-AU	
P2-A26	D6-AV	D6-AW	NOT USED
P2-S27	D6-AX	D6-AY	USED
P2-C28	DAC 20+	D6-AZ	
P2-A29	DAC 20-	D6-BA	
P2-S30	DAC 21+	D6-BC	
P2-C31	DAC 21-	D6-BD	

ACTUATOR NUMBERS  
ARE SHOWN NEXT TO  
DISCONNECT PANEL  
CONNECTOR PIN  
ASSIGNMENTS

COMPUTER  
DICONNECT  
PANEL  
DAC #5  
SLOT 7  
ORANGE

P2-C7	DAC 0+	D7-V	150
P2-A7	DAC 1+	D7-K	148
P2-S8	DAC 1-	D7-M	139A
P2-C9	D7-P	D7-N	139B
P2-A9	D7-R	D7-S	141A
P2-C10	D7-T	D7-U	141B
P2-A11	D7-V	D7-W	132A
P2-S12	D7-X	D7-Y	132B
P2-C13	D6-V	D6-W	130A
P2-A14	D6-X	D6-Y	130B
P2-S15	D6-Z	D6-AA	124
P2-C16	D6-AB	D6-AC	122A
P2-A17	D6-AD	D6-AE	122B
P2-S18	D6-AF	D6-AG	114A
P2-C19	D6-AH	D6-AI	114B
P2-A20	D6-AJ	D6-AK	120
P2-S21	D6-AL	D6-AM	112A
P2-C22	D6-AN	D6-AO	112B
P2-A23	D6-AP	D6-AQ	14
P2-S24	D6-AR	D6-AS	
P2-C25	D6-AT	D6-AU	NOT USED
P2-A26	D6-AV	D6-AW	
P2-S27	D6-AX	D6-AY	
P2-C28	DAC 20+	D6-AZ	
P2-A29	DAC 20-	D6-BA	
P2-S30	DAC 21+	D6-BC	
P2-C31	DAC 21-	D6-BD	

COMPUTER  
DICONNECT  
PANEL  
DAC #7  
SLOT 9  
YELLOW

P2-C7	DAC 0+	D7-V	147
P2-A7	DAC 1+	D7-K	140A
P2-S8	DAC 1-	D7-M	140B
P2-C9	D7-P	D7-N	129
P2-A9	D7-R	D7-S	142A
P2-C10	D7-T	D7-U	142B
P2-A11	D7-V	D7-W	133
P2-S12	D7-X	D7-Y	131A
P2-C13	D6-V	D6-W	131B
P2-A14	D6-X	D6-Y	123A
P2-S15	D6-Z	D6-AA	123B
P2-C16	D6-AB	D6-AC	121A
P2-A17	D6-AD	D6-AE	121B
P2-S18	D6-AF	D6-AG	113A
P2-C19	D6-AH	D6-AI	113B
P2-A20	D6-AJ	D6-AK	111A
P2-S21	D6-AL	D6-AM	111B
P2-C22	D6-AN	D6-AO	15
P2-A23	D6-AP	D6-AQ	11
P2-S24	D6-AR	D6-AS	
P2-C25	D6-AT	D6-AU	NOT USED
P2-A26	D6-AV	D6-AW	
P2-S27	D6-AX	D6-AY	
P2-C28	DAC 20+	D6-AZ	
P2-A29	DAC 20-	D6-BA	
P2-S30	DAC 21+	D6-BC	
P2-C31	DAC 21-	D6-BD	



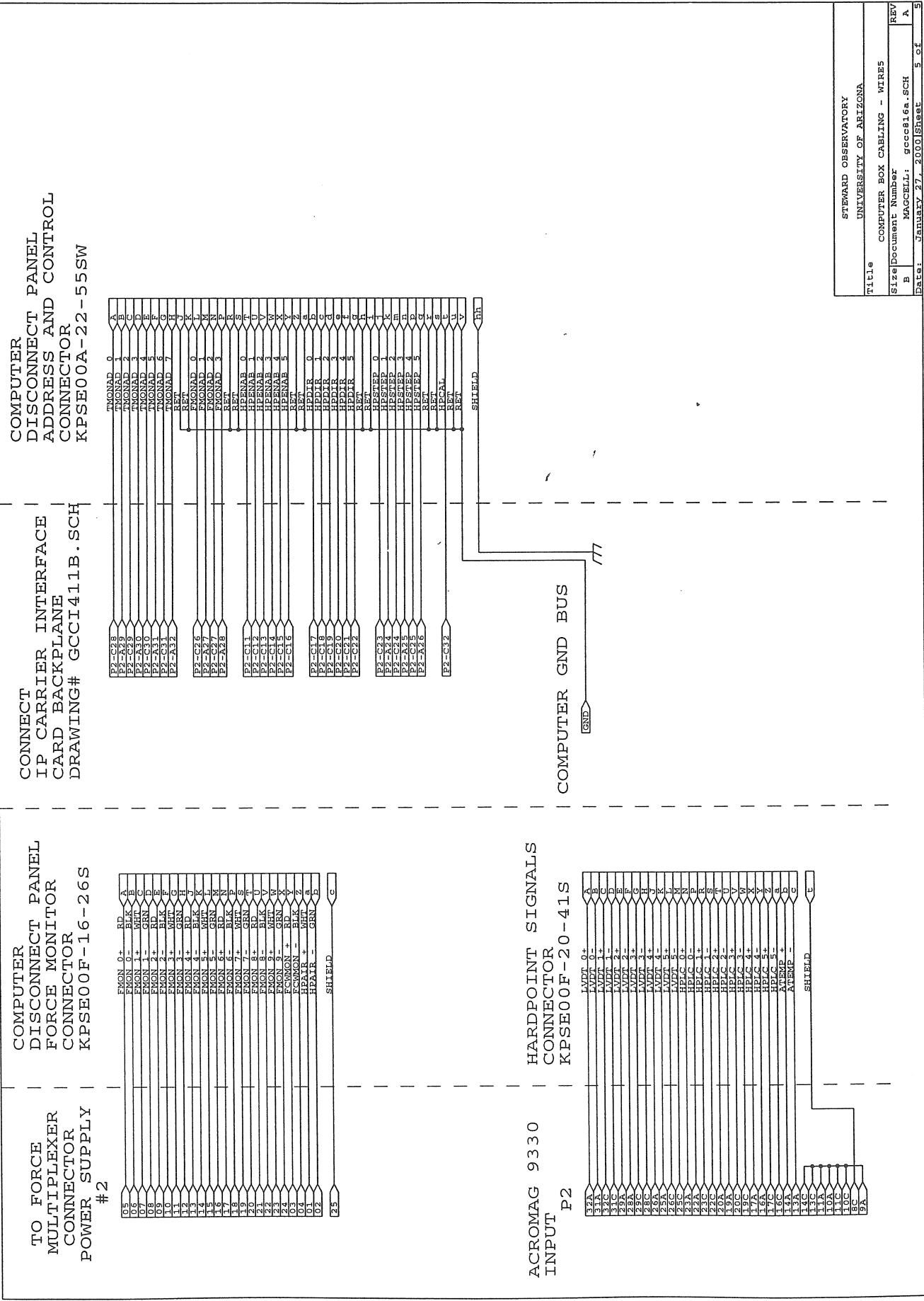

TO FORCE MULTIPLEXER POWER SUPPLY #2

COMPUTER DISCONNECT PANEL FORCE MONITOR CONNECTOR KPSE00F-16-26S

CONNECT IP CARRIER INTERFACE CARD BACKPLANE DRAWING# GCC1411B.SCH

COMPUTER DISCONNECT PANEL ADDRESS AND CONTROL CONNECTOR KPSE00A-22-55SW

COMPUTER DISCONNECT PANEL FORCE MONITOR CONNECTOR KPSE00F-16-26S

ACROMAG 9330 INPUT P2

HARDPOINT SIGNALS CONNECTOR KPSE00F-20-41S

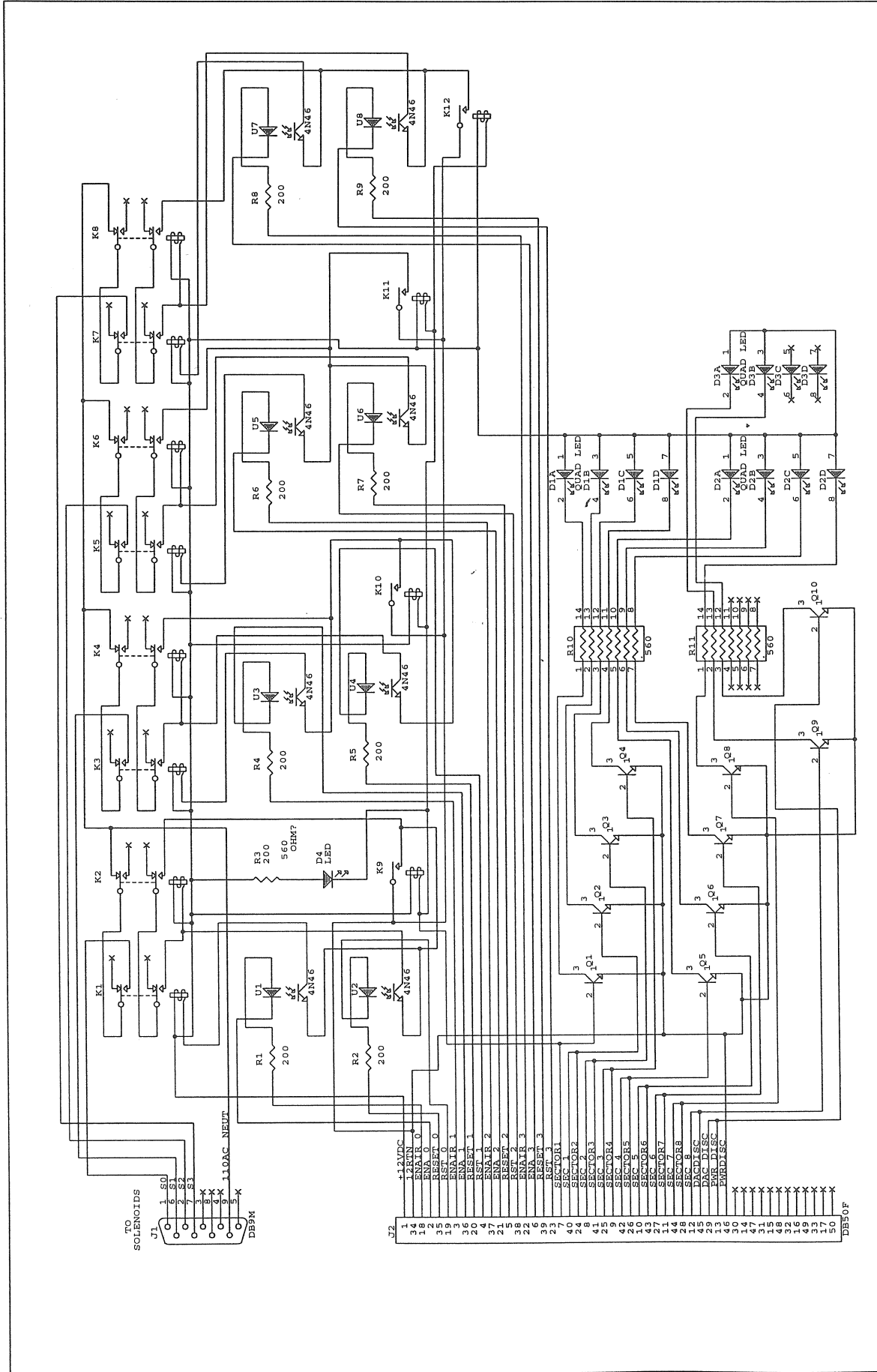

STEWART OBSERVATORY  
 UNIVERSITY OF ARIZONA  
 TUCSON AZ 85721

Title CELL AIR CONTROL BOX

Size Document Number B MACCELL: gcar411a.sch

Date: JANUARY 27, 2000 Sheet 1 of 1

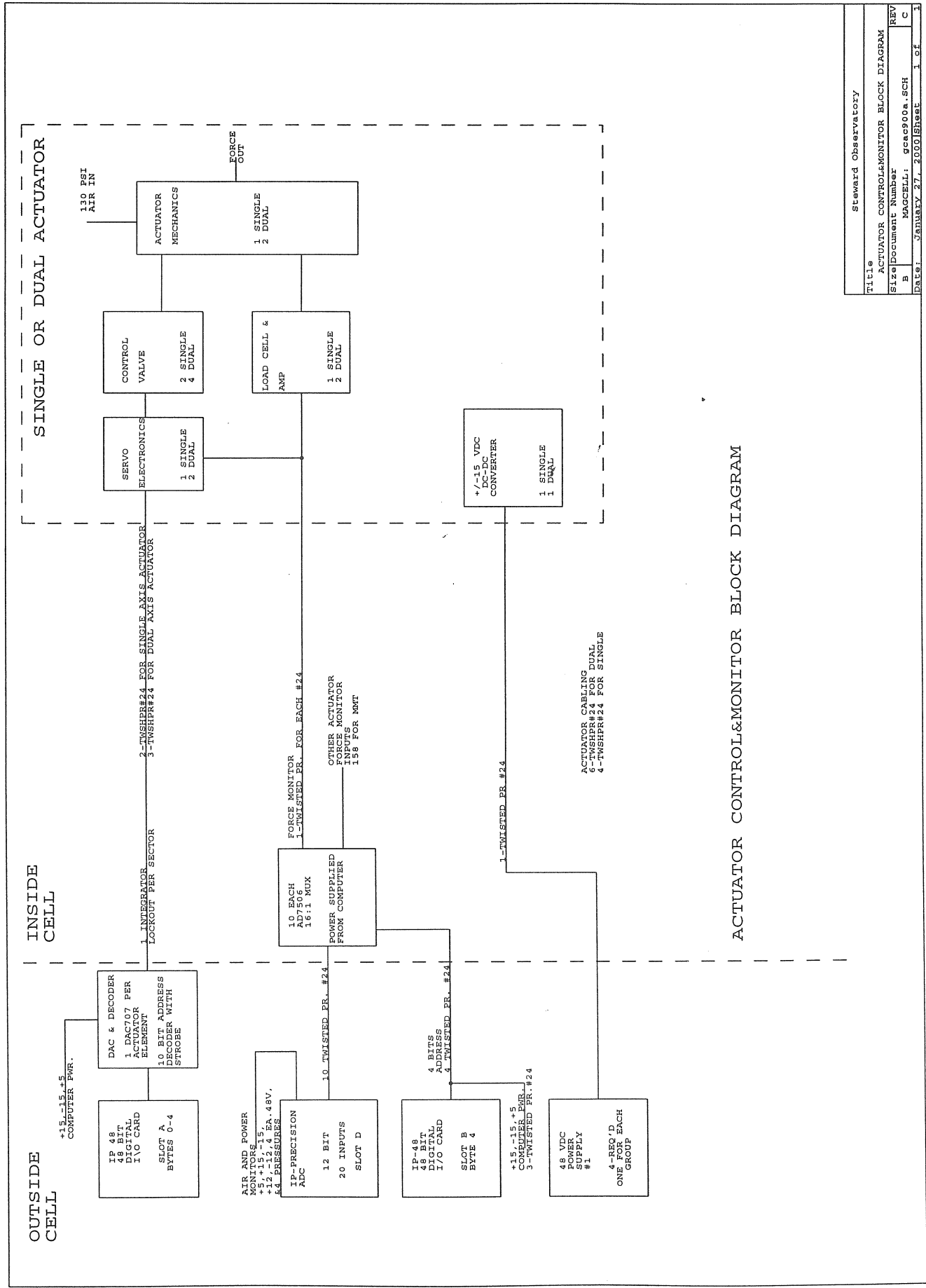

ACTUATOR CONTROL & MONITOR BLOCK DIAGRAM

Steward Observatory	
Title	ACTUATOR CONTROL & MONITOR BLOCK DIAGRAM
Size	Document Number
B	MAGCELL: gca900a.sch
C	Date: January 27, 2000
1	Sheet 1 of 1

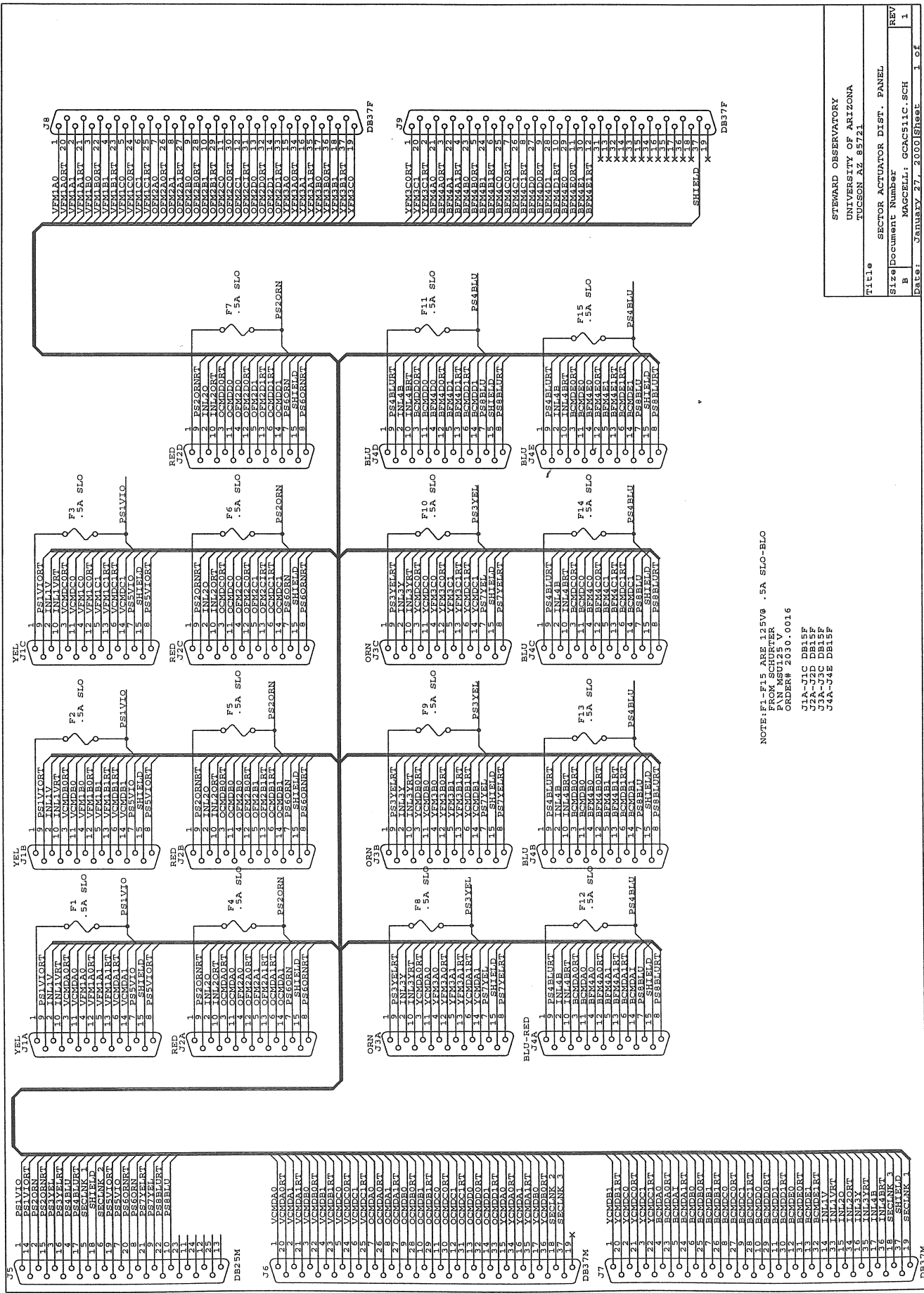

NOTE F1-F15 ARE 125V0 .5A SLO-BLO  
 FROM SCHURER  
 PAN MSUI25 V  
 ORDER# 2030.0016

J1A-J1C DB15F  
 J2A-J2C DB15F  
 J3A-J3C DB15F  
 J4A-J4E DB15F

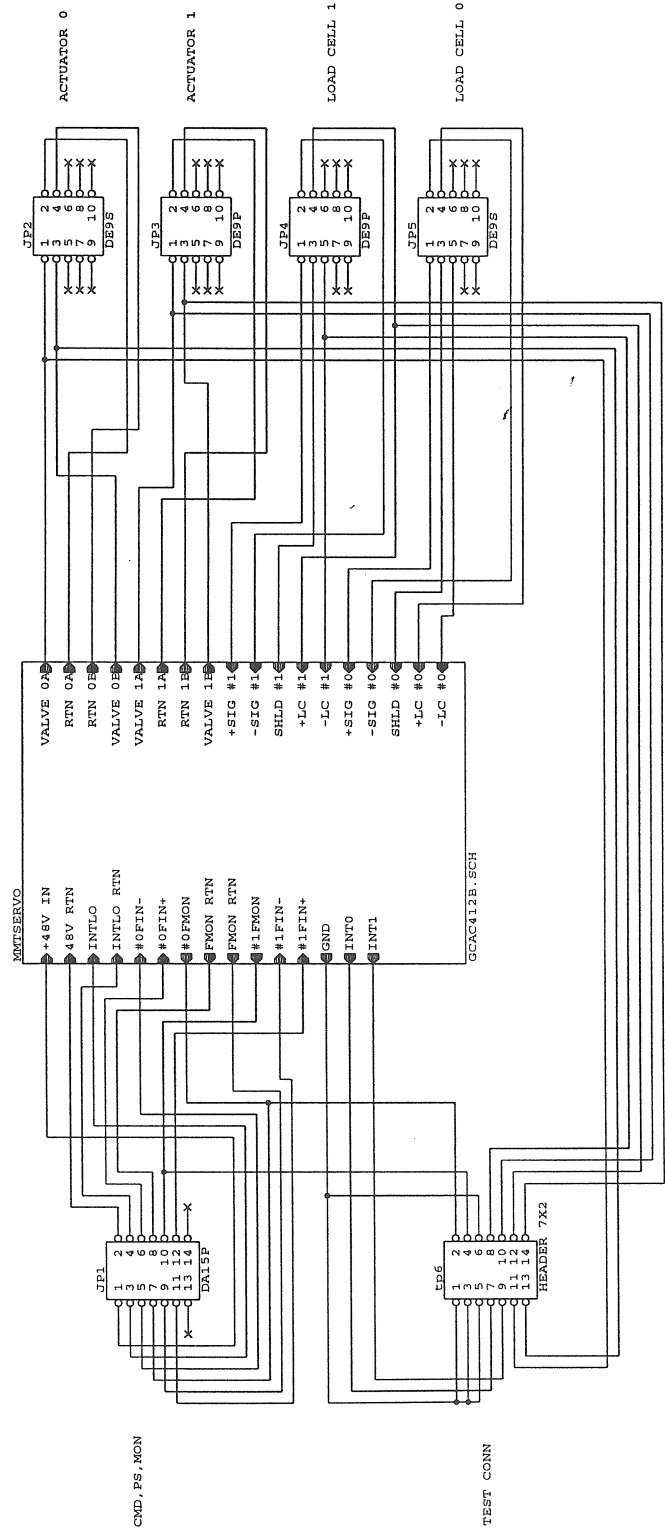

STEWART OBSERVATORY	
UNIVERSITY OF ARIZONA, TUCSON, AZ 85721	
Title	6.5M DUAL-AXIS SERVO ACTUATOR CARD
Size	Document Number
B	MACCELL: gsc411b.sch
REV	B
Date:	January 27, 2000 Sheet 1 of 2

\*\* All positions refer to telescope at zenith.  
 \* Initial startup (cmd = 0) opens both push and  
 1/2 max psi. half way. Both valves have  
 \* 0V on FIN- & +V on FIN+ will push mirror up  
 \* 0V on FIN- & -V on FIN+ will pull mirror down  
 \* Valve outputs are limited by zener diodes  
 \* Load cell is tension upscale

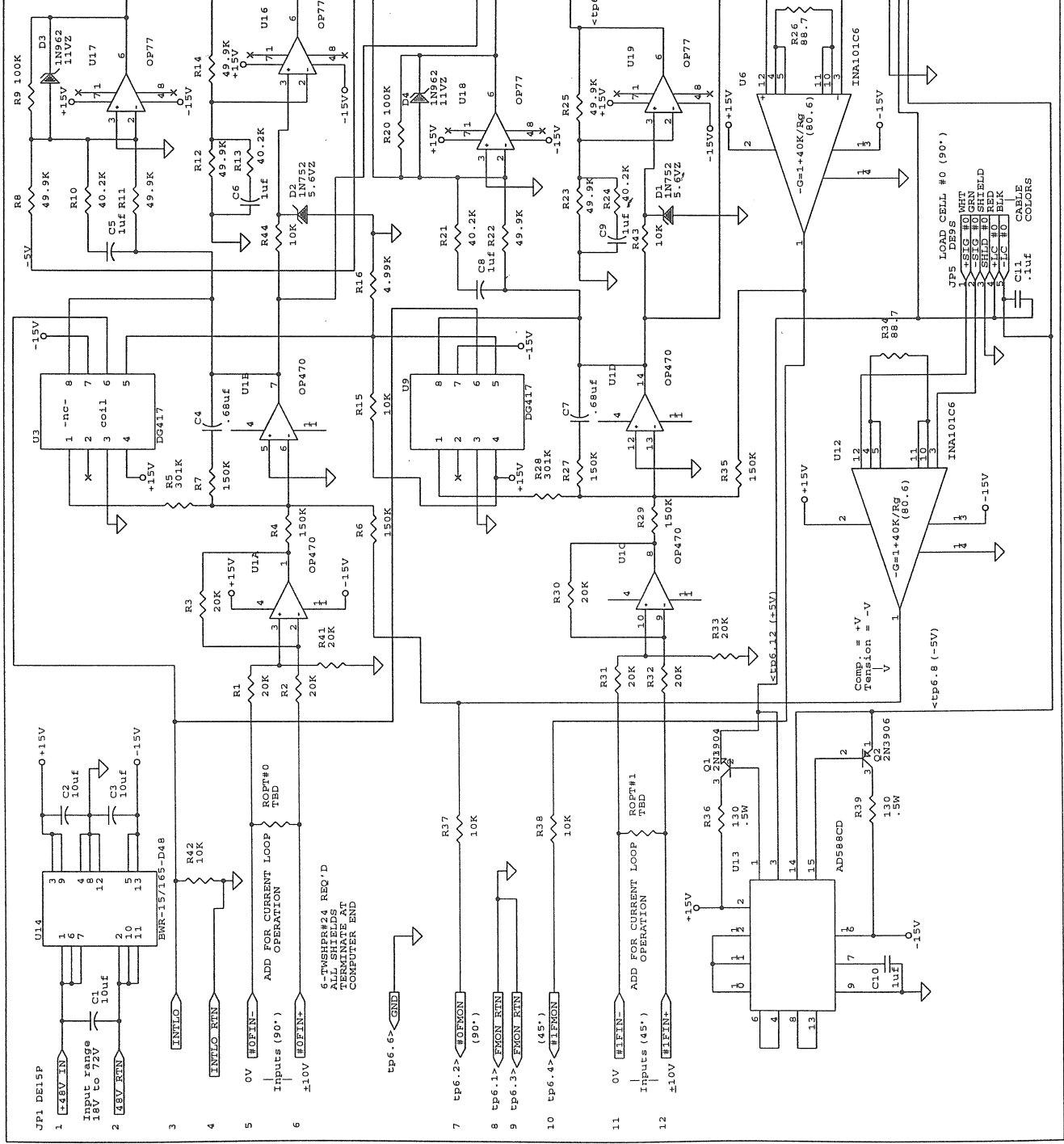

ACTUATOR #0 (90°)  
 1 VALVE OA BLK Valve A pulls mirror down  
 2 VALVE OB WHT Valve B pushes mirror up.  
 3 VALVE OB BLK Valve B pushes mirror up.  
 4 FIN OB WHT CABLE COLORS

ACTUATOR #1 (45°)  
 1 VALVE 1A BLK  
 2 VALVE 1B WHT  
 3 VALVE 1A BLK  
 4 VALVE 1B WHT  
 CABLE COLORS

LOAD CELL #1 (45°)  
 1 SIG #1 WHT  
 2 SIG #1 GRN  
 3 SHLD #1 SHIELD  
 4 EC #1 RED  
 5 EC #1 BLK  
 CABLE COLORS

LOAD CELL #0 (90°)  
 1 SIG #0 WHT  
 2 SIG #0 GRN  
 3 SHLD #0 SHIELD  
 4 EC #0 RED  
 5 EC #0 BLK  
 CABLE COLORS



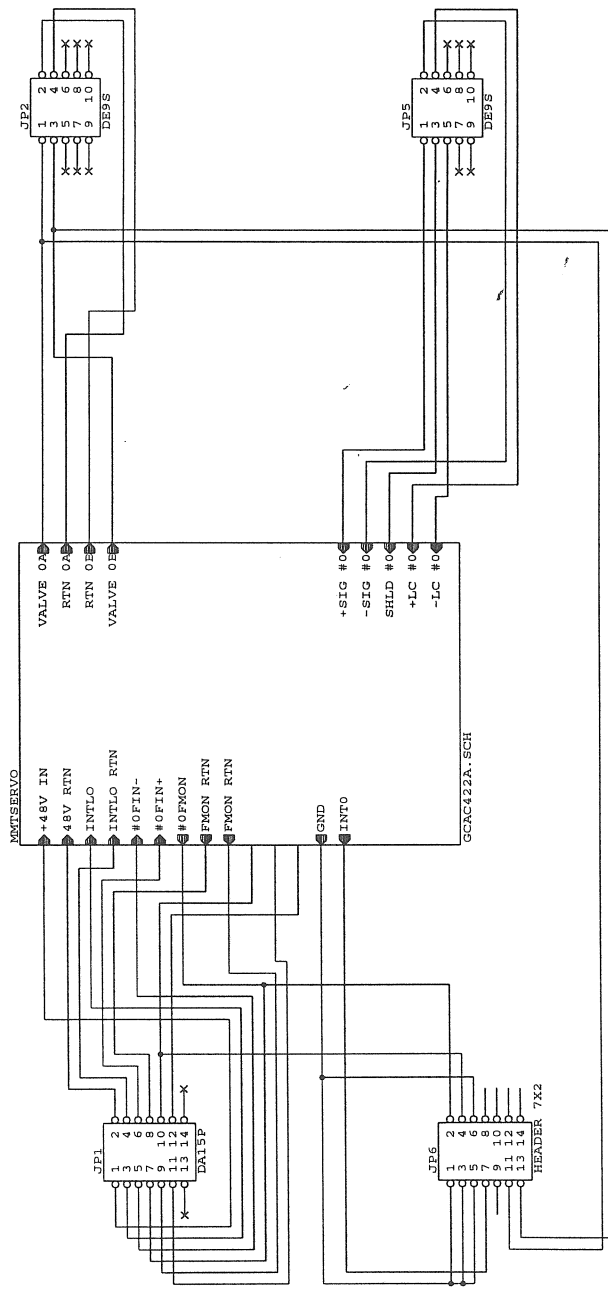



DB15P  
SECTOR  
DISTRIBUTION  
PANEL  
CONNECTOR

DB15S  
SINGLE AXIS  
ACTUATOR  
CONNECTOR

1	48V	RED
2	INTLO	BLK
3	INTLO	WHI
4	INTLO	WHI
5	INTLO	WHI
6	INTLO	WHI
7	INTLO	WHI
8	INTLO	WHI
9	INTLO	WHI
10	INTLO	WHI
11	INTLO	WHI
12	INTLO	WHI
13	INTLO	WHI
14	INTLO	WHI
15	SHIELD	

4-TW-PR-#24-OVR SHIELD

DB15P  
SECTOR  
DISTRIBUTION  
PANEL  
CONNECTOR

DB15S  
DUAL AXIS  
ACTUATOR  
CONNECTOR

1	+48V	RED
2	48RTN	BLK
3	INTLO	BLK
4	INTLO	BLK
5	INTLO	BLK
6	INTLO	BLK
7	INTLO	BLK
8	INTLO	BLK
9	INTLO	BLK
10	INTLO	BLK
11	INTLO	BLK
12	INTLO	BLK
13	INTLO	BLK
14	INTLO	BLK
15	SHIELD	

6-TW-PR-#24-OVR SHIELD



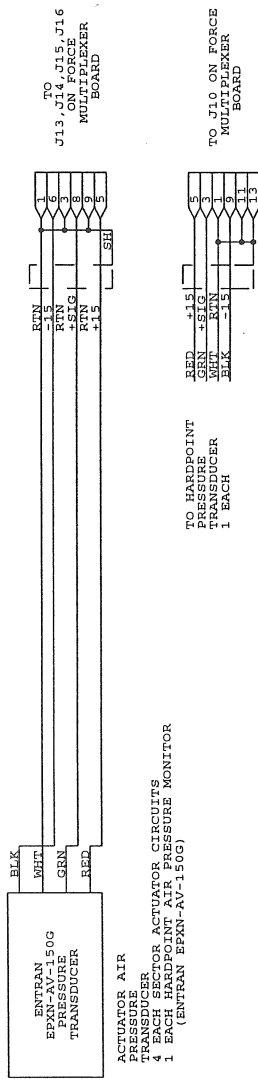

STEWART OBSERVATORY	
UNIVERSITY OF ARIZONA	
Title	AIR PRESSURE MONITORS (ACT & HP) WIRE DIAG.
Size	Document Number
B	MACCELL: gcmms11a.sch
REV	A
Date:	January 27, 2000
Sheet	1 of 1

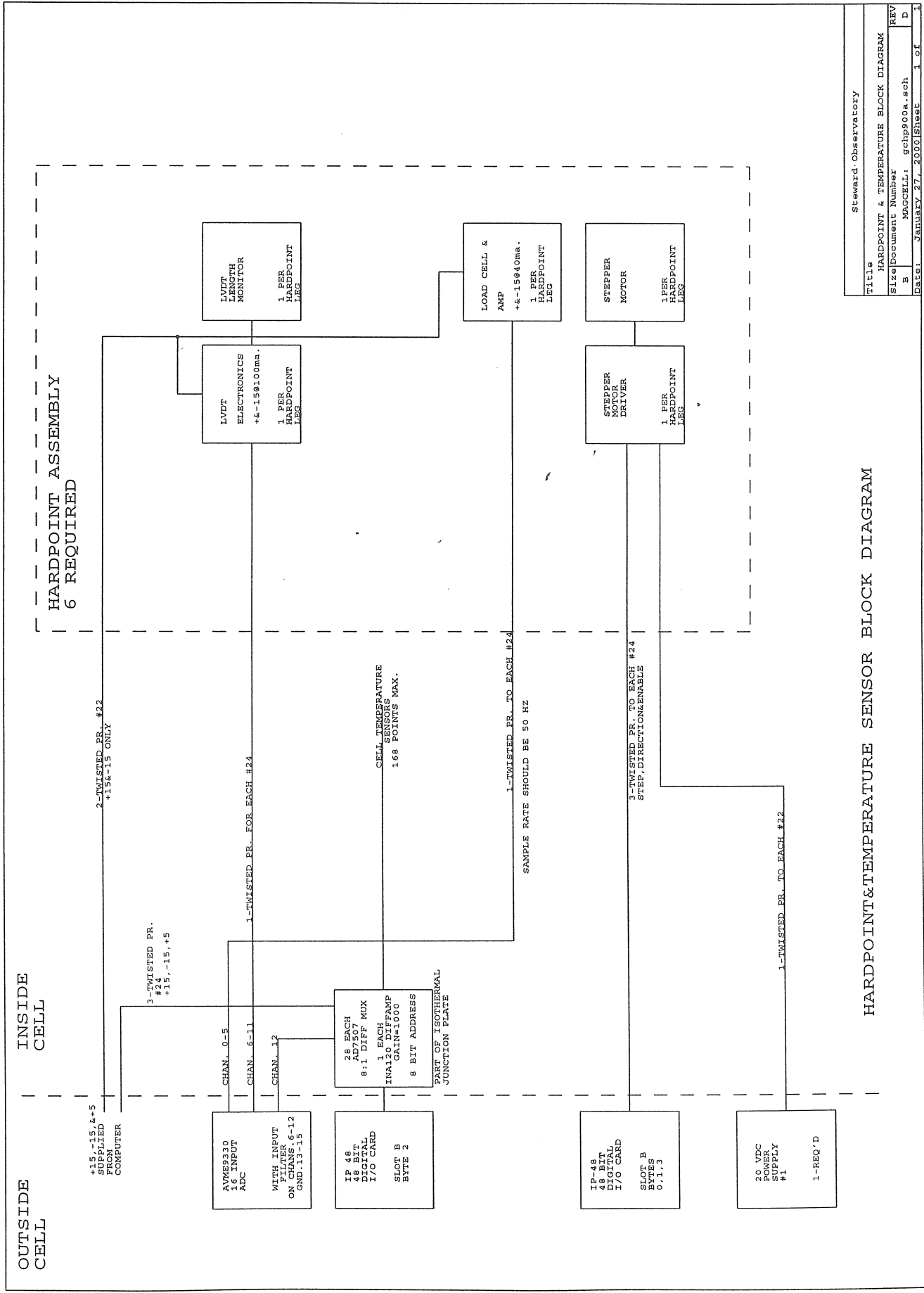

HARDPOINT & TEMPERATURE SENSOR BLOCK DIAGRAM

Steward-Observatory	
Title	HARDPOINT & TEMPERATURE BLOCK DIAGRAM
Size	Document Number
B	MACCELL: gchp900a.sch
D	REV
Date: January 27, 2000	Sheet 1 of 1

Digital Control from IP-48 slot C  
via Comp Intri p/c 23-57A

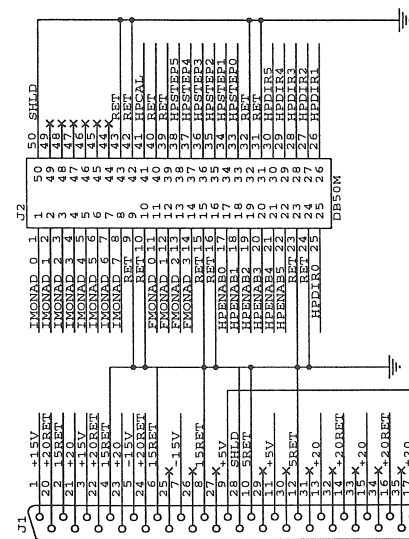

To Hardpoint #0  
times 2., LVD1, and Stepper Control

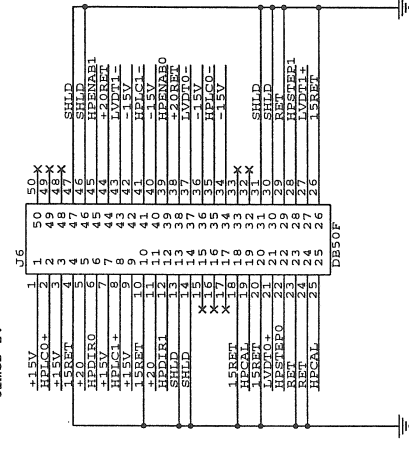

To Hardpoint #1  
times 2., LVD1, and Stepper Control

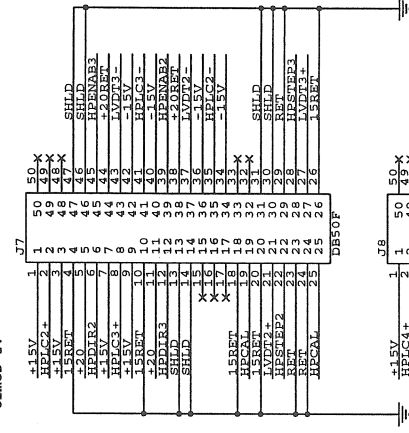

Position,  
force, and  
temp info  
to ADC9330  
Computer  
Interface  
Plate 23-37S

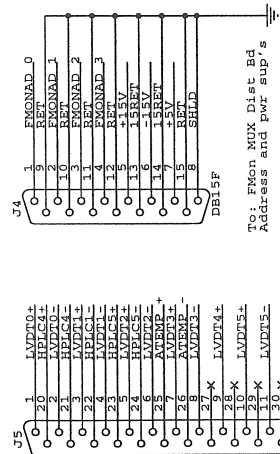

To: TMon MUX  
address, and  
to: mux input.

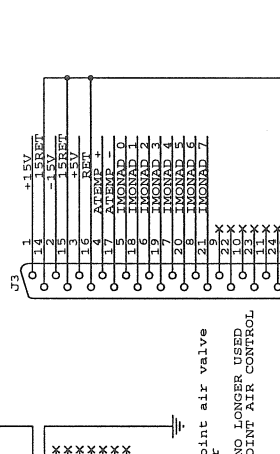

To Hardpoint #2  
times 2., LVD1, and Stepper Control

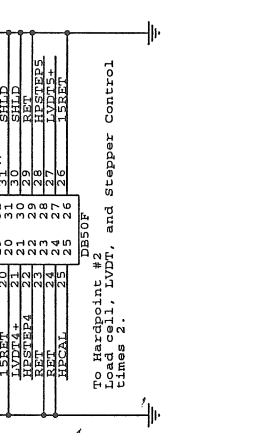





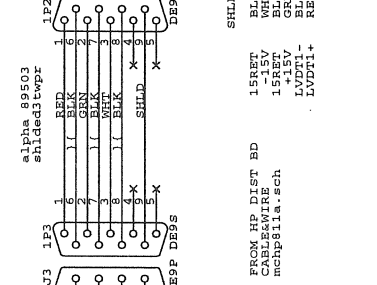
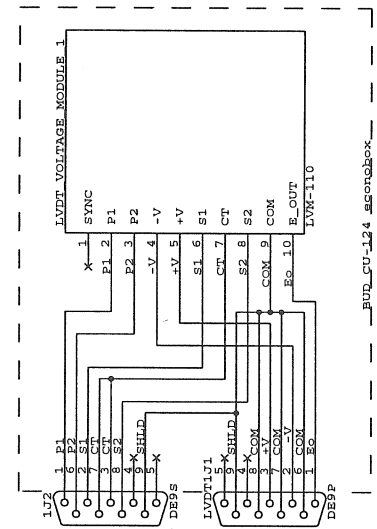

0J2 AND 0J2 must have socket & plugged on each of them for keying purposes.

conn. Pinout at  
HP ITEM, FROM, PWR DIST BOARD  
HP\_P6/7/8

STPR  
HELC  
LVD1

- 50 LVD1
- 49
- 48
- 47 SHLD
- 46 SHLD
- 45 SHLD
- 44 HPENAB1
- 43 RET
- 42 HPENAB0
- 41 HPSTEF1
- 40 -15V RET
- 39 HPENAB0
- 38 +20RET
- 37 HPSTEF0
- 36 LVD1+
- 35 LVD1-
- 34 HPENAB1
- 33 HPENAB0
- 32 HPENAB1
- 31 HPENAB0
- 30 HPSTEF1
- 29 HPSTEF0
- 28 HPENAB1
- 27 HPENAB0
- 26 HPENAB1
- 25 HPENAB0
- 24 HPENAB1
- 23 HPENAB0
- 22 HPENAB1
- 21 HPENAB0
- 20 HPENAB1
- 19 HPENAB0
- 18 HPENAB1
- 17 HPENAB0
- 16 HPENAB1
- 15 HPENAB0
- 14 HPENAB1
- 13 HPENAB0
- 12 HPENAB1
- 11 HPENAB0
- 10 HPENAB1
- 9 HPENAB0
- 8 HPENAB1
- 7 HPENAB0
- 6 HPENAB1
- 5 HPENAB0
- 4 HPENAB1
- 3 HPENAB0
- 2 HPENAB1
- 1 HPENAB0

STEWART OBSERVATORY  
UNIVERSITY OF ARIZONA  
TUCSON AZ 85721

Title  
HP-LVD1 ELECTRONICS  
Size Document Number  
B MAGCELL: GCHP521A.SCH  
REV  
A  
Date: January 27, 2001 Sheet 1 of 1

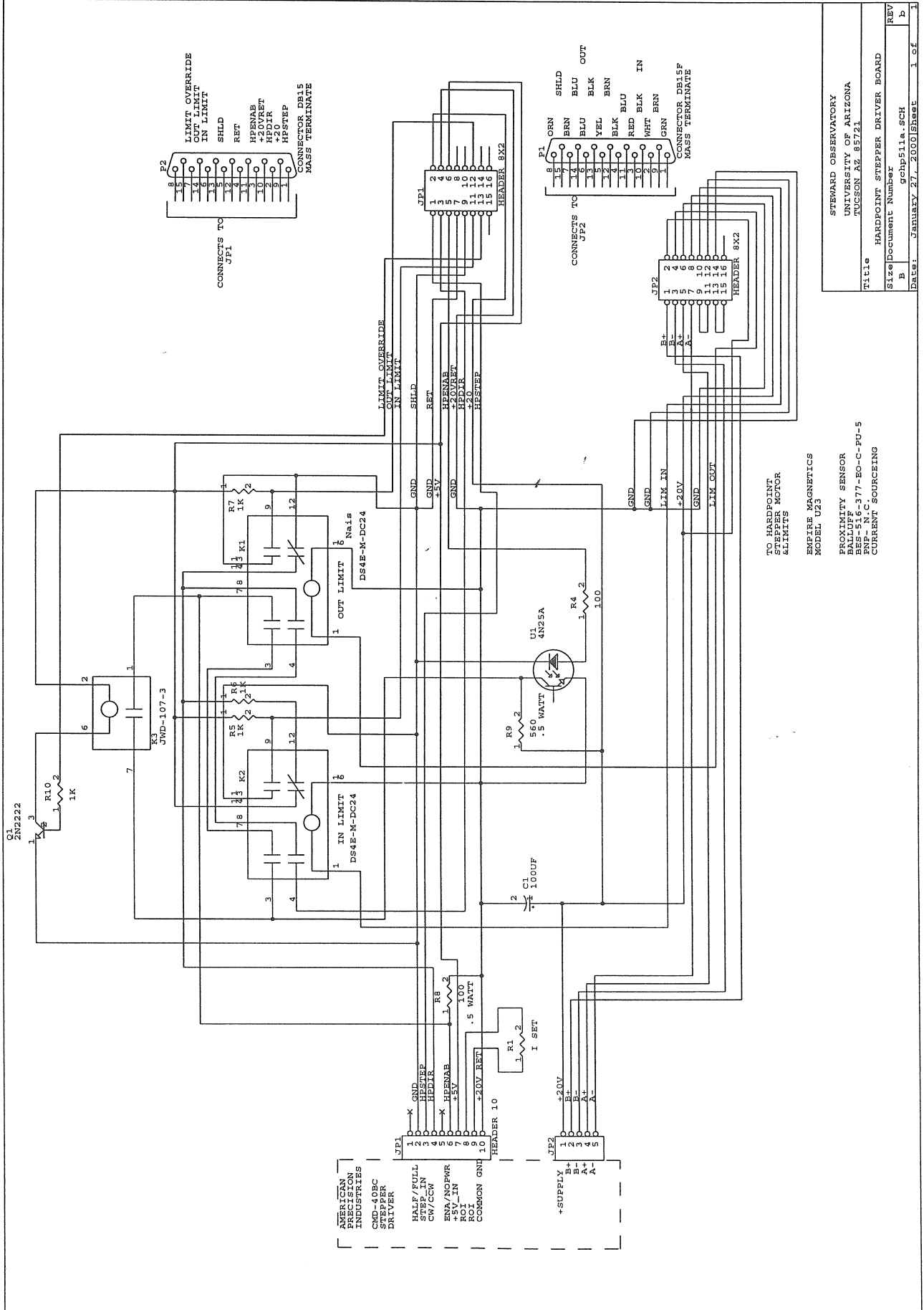

STEWART OBSERVATORY  
UNIVERSITY OF ARIZONA  
TUCSON, AZ 85721

Title  
Size  
B  
Date: January 27, 2000

Hardpoint Stepper Driver Board  
gchp511a.sch  
1 of 1

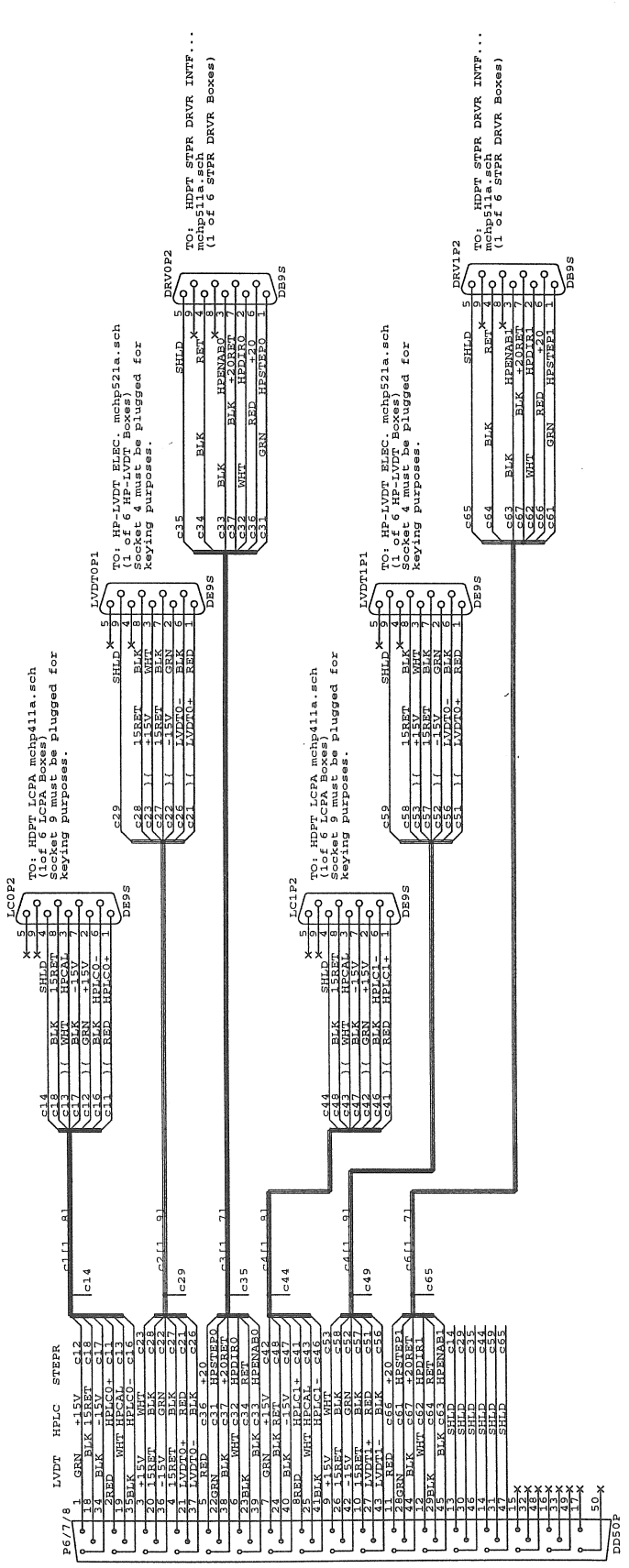

TO: HDFT STPR DRVR INTF... (1 of 6 HP-LVDT Boxes)

TO: HDFT STPR DRVR INTF... (1 of 6 STPR DRVR Boxes)

TO: HDFT STPR DRVR INTF... (1 of 6 HP-LVDT Boxes)

TO: HDFT STPR DRVR INTF... (1 of 6 STPR DRVR Boxes)

NOTES:  
 Cables c1 thru c6 are Alpha 89503 shielded 3TWP1.  
 This schem defines one of 3 HDFT Cable harnesses (P6, P7, P8) for each hardpoint pair in the cell.

This connector plugs into the HP,TEMP, FMGN, POWER DISTRIBUTION PANEL mcad511a.sch J6 or J7 or J8.

STEWART OBSERVATORY UNIVERSITY OF ARIZONA TUCSON, AZ 85721	
Title	HDPT CABLEWIRE
Size/Document Number	gchp511a.sch
B	MAGCELL: gchp511a.sch
Date:	January 27, 2000
Sheet	1 of 1

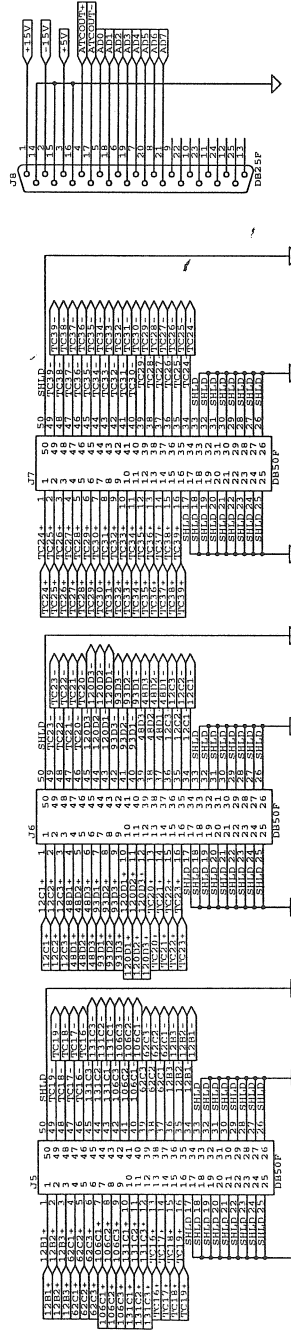
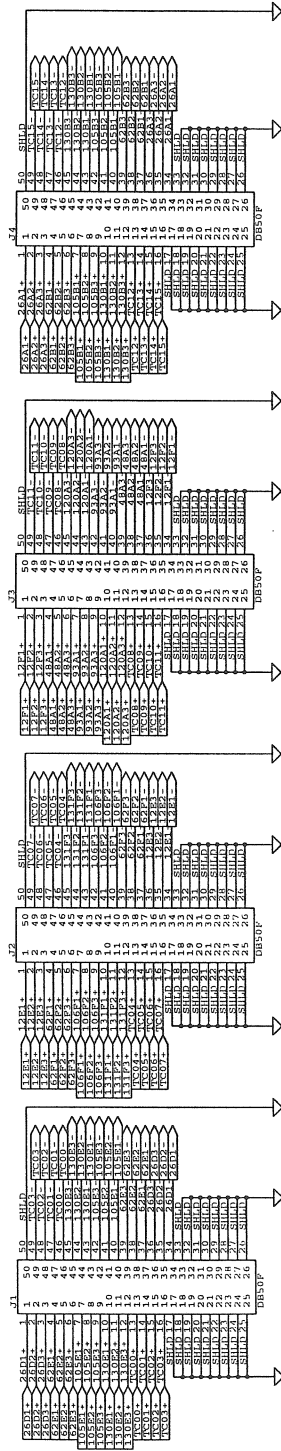

LINK | gcaps2a.sch



SECTOR #1

PO  
KPS00F-22-215

A	RD	48V-1
B	BLK	48V-1
C	WHT	48V-2
D	GRN	48V-2
E	BLK	48V-2
F	WHT	48V-3
G	BLK	48V-3
H	GRN	48V-3
I	BLU	48V-4
J	BLK	SHIELD
K	WHT	SHIELD

PO  
KPS00F-24-615

A	BLU	1
B	BLK	2
C	WHT	3
D	GRN	4
E	BLK	5
F	WHT	6
G	BLK	7
H	GRN	8
I	BLU	9
J	BLK	10
K	WHT	11
L	GRN	12
M	BLK	13
N	WHT	14
O	BLK	15
P	GRN	16
Q	BLU	17
R	BLK	18
S	WHT	19
T	GRN	20
U	BLK	21
V	WHT	22
W	BLK	23
X	GRN	24
Y	BLU	25
Z	BLK	26
AA	WHT	27
AB	GRN	28
AC	BLU	29
AD	BLK	30
AE	WHT	31
AF	GRN	32
AG	BLU	33
AH	BLK	34
AI	WHT	35
AJ	GRN	36
AK	BLU	37
AL	BLK	38
AM	WHT	39
AN	GRN	40
AO	BLU	41
AP	BLK	42
AQ	WHT	43
AR	GRN	44
AS	BLU	45
AT	BLK	46
AU	WHT	47
AV	GRN	48
AW	BLU	49
AX	BLK	50
AY	WHT	51
AZ	GRN	52
BA	BLU	53
BB	BLK	54
BC	WHT	55
BD	GRN	56
BE	BLU	57
BF	BLK	58
BG	WHT	59
BH	GRN	60
BI	BLU	61
BJ	BLK	62
BK	WHT	63
BL	SHIELD	64
BM	SHIELD	65

CABEL 156-1J7

0	1	ESVIO	RD
0	2	ESVIORT	BLK
0	3	ESVORNET	BLK
0	4	ESVVEL	GRN
0	5	ESVVELT	BLK
0	6	ESVVELT	BLK
0	7	ESVVELT	BLK
0	8	ESVVELT	BLK
0	9	ESVVELT	BLK
0	10	ESVVELT	BLK
0	11	ESVVELT	BLK
0	12	ESVVELT	BLK
0	13	ESVVELT	BLK
0	14	ESVVELT	BLK
0	15	ESVVELT	BLK
0	16	ESVVELT	BLK
0	17	SHIELD	
0	18	SHIELD	

0	1	VCMDA0	WHT
0	2	VCMDA0	ORNG
0	3	VCMDA1	WHT
0	4	VCMDA1	WHT
0	5	VCMDA1	WHT
0	6	VCMDA1	WHT
0	7	VCMDA1	WHT
0	8	VCMDA1	WHT
0	9	VCMDA1	WHT
0	10	VCMDA1	WHT
0	11	VCMDA1	WHT
0	12	VCMDA1	WHT
0	13	VCMDA1	WHT
0	14	VCMDA1	WHT
0	15	VCMDA1	WHT
0	16	VCMDA1	WHT
0	17	VCMDA1	WHT
0	18	VCMDA1	WHT
0	19	VCMDA1	WHT
0	20	VCMDA1	WHT
0	21	VCMDA1	WHT
0	22	VCMDA1	WHT
0	23	VCMDA1	WHT
0	24	VCMDA1	WHT
0	25	VCMDA1	WHT
0	26	VCMDA1	WHT
0	27	VCMDA1	WHT
0	28	VCMDA1	WHT
0	29	VCMDA1	WHT
0	30	VCMDA1	WHT
0	31	VCMDA1	WHT
0	32	VCMDA1	WHT
0	33	VCMDA1	WHT
0	34	VCMDA1	WHT
0	35	VCMDA1	WHT
0	36	VCMDA1	WHT
0	37	VCMDA1	WHT
0	38	VCMDA1	WHT
0	39	VCMDA1	WHT
0	40	VCMDA1	WHT
0	41	VCMDA1	WHT
0	42	VCMDA1	WHT
0	43	VCMDA1	WHT
0	44	VCMDA1	WHT
0	45	VCMDA1	WHT
0	46	VCMDA1	WHT
0	47	VCMDA1	WHT
0	48	VCMDA1	WHT
0	49	VCMDA1	WHT
0	50	VCMDA1	WHT
0	51	VCMDA1	WHT
0	52	VCMDA1	WHT
0	53	VCMDA1	WHT
0	54	VCMDA1	WHT
0	55	VCMDA1	WHT
0	56	VCMDA1	WHT
0	57	VCMDA1	WHT
0	58	VCMDA1	WHT
0	59	VCMDA1	WHT
0	60	VCMDA1	WHT
0	61	VCMDA1	WHT
0	62	VCMDA1	WHT
0	63	VCMDA1	WHT
0	64	VCMDA1	WHT
0	65	VCMDA1	WHT
0	66	VCMDA1	WHT
0	67	VCMDA1	WHT
0	68	VCMDA1	WHT
0	69	VCMDA1	WHT
0	70	VCMDA1	WHT
0	71	VCMDA1	WHT
0	72	VCMDA1	WHT
0	73	VCMDA1	WHT
0	74	VCMDA1	WHT
0	75	VCMDA1	WHT
0	76	VCMDA1	WHT
0	77	VCMDA1	WHT
0	78	VCMDA1	WHT
0	79	VCMDA1	WHT
0	80	VCMDA1	WHT
0	81	VCMDA1	WHT
0	82	VCMDA1	WHT
0	83	VCMDA1	WHT
0	84	VCMDA1	WHT
0	85	VCMDA1	WHT
0	86	VCMDA1	WHT
0	87	VCMDA1	WHT
0	88	VCMDA1	WHT
0	89	VCMDA1	WHT
0	90	VCMDA1	WHT
0	91	VCMDA1	WHT
0	92	VCMDA1	WHT
0	93	VCMDA1	WHT
0	94	VCMDA1	WHT
0	95	VCMDA1	WHT
0	96	VCMDA1	WHT
0	97	VCMDA1	WHT
0	98	VCMDA1	WHT
0	99	VCMDA1	WHT
0	100	VCMDA1	WHT

0	1	VCMDA1	WHT
0	2	VCMDA1	WHT
0	3	VCMDA1	WHT
0	4	VCMDA1	WHT
0	5	VCMDA1	WHT
0	6	VCMDA1	WHT
0	7	VCMDA1	WHT
0	8	VCMDA1	WHT
0	9	VCMDA1	WHT
0	10	VCMDA1	WHT
0	11	VCMDA1	WHT
0	12	VCMDA1	WHT
0	13	VCMDA1	WHT
0	14	VCMDA1	WHT
0	15	VCMDA1	WHT
0	16	VCMDA1	WHT
0	17	VCMDA1	WHT
0	18	VCMDA1	WHT
0	19	VCMDA1	WHT
0	20	VCMDA1	WHT
0	21	VCMDA1	WHT
0	22	VCMDA1	WHT
0	23	VCMDA1	WHT
0	24	VCMDA1	WHT
0	25	VCMDA1	WHT
0	26	VCMDA1	WHT
0	27	VCMDA1	WHT
0	28	VCMDA1	WHT
0	29	VCMDA1	WHT
0	30	VCMDA1	WHT
0	31	VCMDA1	WHT
0	32	VCMDA1	WHT
0	33	VCMDA1	WHT
0	34	VCMDA1	WHT
0	35	VCMDA1	WHT
0	36	VCMDA1	WHT
0	37	VCMDA1	WHT
0	38	VCMDA1	WHT
0	39	VCMDA1	WHT
0	40	VCMDA1	WHT
0	41	VCMDA1	WHT
0	42	VCMDA1	WHT
0	43	VCMDA1	WHT
0	44	VCMDA1	WHT
0	45	VCMDA1	WHT
0	46	VCMDA1	WHT
0	47	VCMDA1	WHT
0	48	VCMDA1	WHT
0	49	VCMDA1	WHT
0	50	VCMDA1	WHT
0	51	VCMDA1	WHT
0	52	VCMDA1	WHT
0	53	VCMDA1	WHT
0	54	VCMDA1	WHT
0	55	VCMDA1	WHT
0	56	VCMDA1	WHT
0	57	VCMDA1	WHT
0	58	VCMDA1	WHT
0	59	VCMDA1	WHT
0	60	VCMDA1	WHT
0	61	VCMDA1	WHT
0	62	VCMDA1	WHT
0	63	VCMDA1	WHT
0	64	VCMDA1	WHT
0	65	VCMDA1	WHT
0	66	VCMDA1	WHT
0	67	VCMDA1	WHT
0	68	VCMDA1	WHT
0	69	VCMDA1	WHT
0	70	VCMDA1	WHT
0	71	VCMDA1	WHT
0	72	VCMDA1	WHT
0	73	VCMDA1	WHT
0	74	VCMDA1	WHT
0	75	VCMDA1	WHT
0	76	VCMDA1	WHT
0	77	VCMDA1	WHT
0	78	VCMDA1	WHT
0	79	VCMDA1	WHT
0	80	VCMDA1	WHT
0	81	VCMDA1	WHT
0	82	VCMDA1	WHT
0	83	VCMDA1	WHT
0	84	VCMDA1	WHT
0	85	VCMDA1	WHT
0	86	VCMDA1	WHT
0	87	VCMDA1	WHT
0	88	VCMDA1	WHT
0	89	VCMDA1	WHT
0	90	VCMDA1	WHT
0	91	VCMDA1	WHT
0	92	VCMDA1	WHT
0	93	VCMDA1	WHT
0	94	VCMDA1	WHT
0	95	VCMDA1	WHT
0	96	VCMDA1	WHT
0	97	VCMDA1	WHT
0	98	VCMDA1	WHT
0	99	VCMDA1	WHT
0	100	VCMDA1	WHT











SECTOR #6

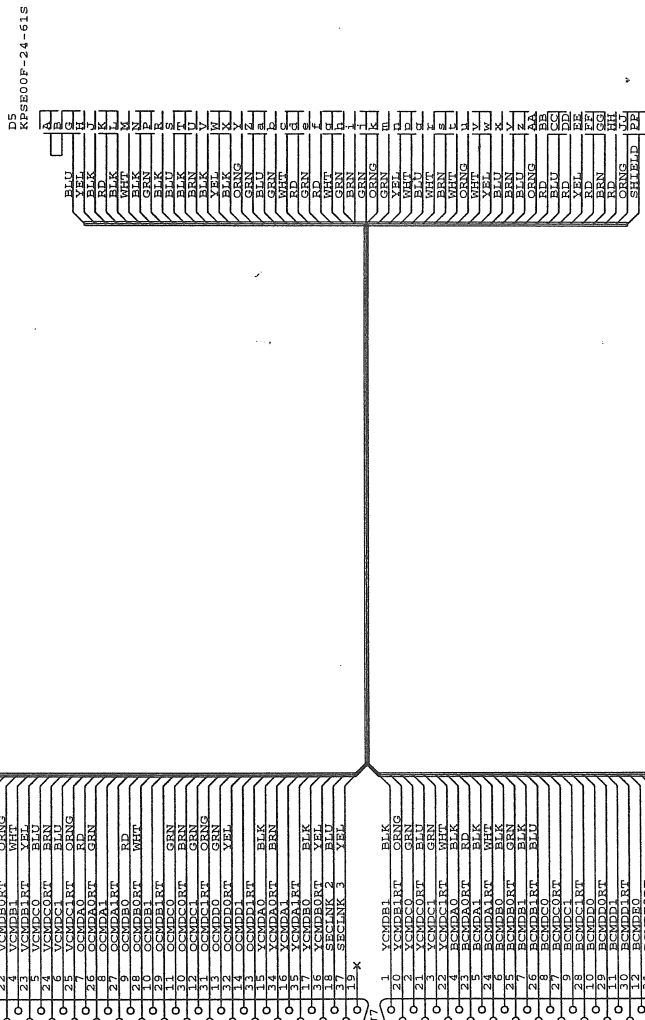
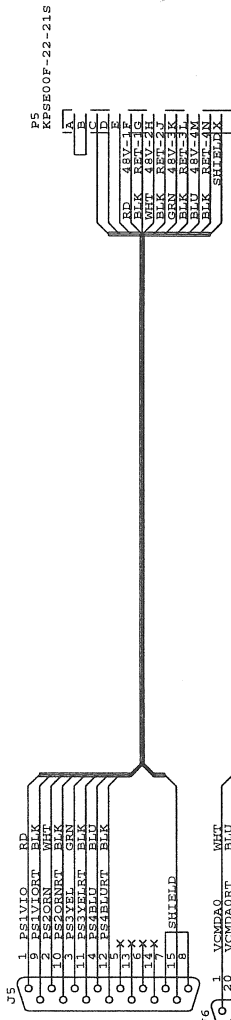

PS  
KPSE00F-22-215

DE  
KPSE00F-24-615

SECTOR #7

